

GAMMATRON TYPE 454

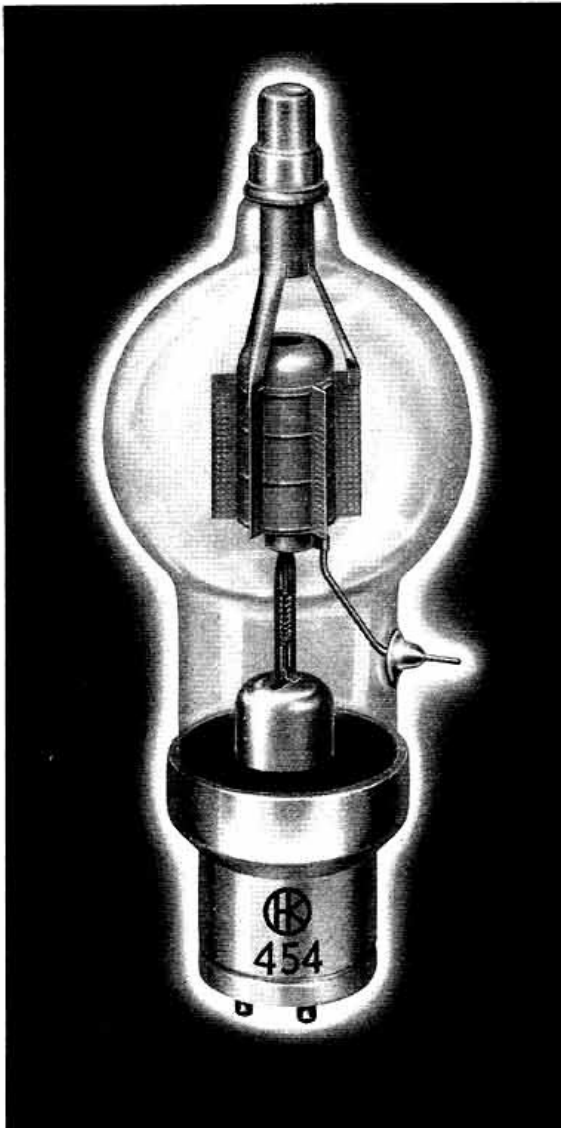

GENERAL PURPOSE TRIODE

250 watt radiation cooled triode, available in two amplification factors: **Low mu** 13.5 and **High mu** 27. Exceptional VHF performance and ability to stand high voltages.

PHYSICAL DATA

Plate	Cylindrical Tantalum
Grid	Braced Vertical Bar Tantalum
Filament	Thoriated Tungsten
Blank	Nonex Glass
Base	Standard Fifty Watt
Net Weight	9 Ounces
Shipping Weight	2½ Pounds
Shipping Volume	0.6 Cu. Feet
Maximum Height	10⅛ Inches
Diameter	3⅓ Inches

ELECTRICAL DATA

	L	H
Filament Voltage	5.0	5.0 Volts
Filament Current	10	10 Amps.
Normal Plate Dissipation	250	250 Watts
Maximum Average Plate Current	375	375 M. A.
Maximum Plate Voltage	5000	5000 Volts
Maximum Average Grid Current	60	85 M. A.
Average Amplification Constant	13.5	27
Grid-Plate Capacitance	3.2	3.5 mmf.
Grid-Filament Capacitance	3.9	4.1 mmf.
Plate-Filament Capacitance	0.7	0.6 mmf.

Unique constructional features make this tube capable of high voltages and of unusual very high frequency performance. It has exceptional ruggedness, electrical stamina, and extra long life.

Copper thimble connectors are used for the plate terminal. They are high current capacity connectors possessing low resistance. Because of improved radiation, they run at least 50 degrees Centigrade cooler at the copper to glass seal than do ordinary tungsten seals. Their design relieves glass strains, and hence the seal positively will not fail. Heavy, rugged leads provide perfect support and alignment to the elements without the use of insulators. Their low inductance com-

bined with low interelectrode capacity provides easy neutralization and reduces circuit losses at high frequencies.

The VHF efficiency is high because of the use of an enclosed plate which confines all electrons to give useful output. Ordinary open plate tubes operate at lower efficiency because of escaped electrons. Electron bombardment is eliminated, lifting voltage limitations. Operation as a neutralized power amplifier up to 150 mc is practical with 70% efficiency.

New tantalum cleaning and pumping techniques give the 454 extra long life, and make it more gas free—more failure proof. A result of 17 years of GAMMATRON progress.

5000 4-46

HEINTZ AND KAUFMAN LTD.

SOUTH SAN FRANCISCO, CALIFORNIA, U. S. A.

TYPE HK 454

The information on this and the following page does not represent exact conditions of operation to be imposed for any particular situation. Because tubes are used under many widely different conditions Heintz and Kaufman will gladly furnish information for applications which differ appreciably from the illustrative examples given.

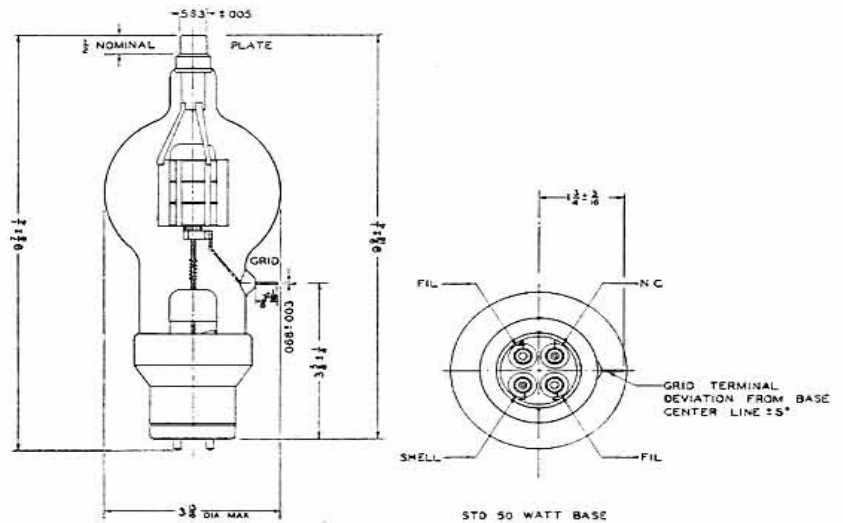

RADIO FREQUENCY POWER AMPLIFIER CLASS "C" UNMODULATED

	L				H			
	Maximum Rating Per Tube	Typical Operation, 1 Tube			Maximum Rating Per Tube	Typical Operation, 1 Tube		
Power Output.....		900	750	525	900	775	540	Watts
Driving Power.....		26	35	40	27	35	40	Watts
DC Plate Voltage.....	5000	4000	3000	2000	5000	4000	3000	2000 Volts
DC Plate Current.....	375	280	325	375	375	280	335	375 ma
DC Grid Current.....	60	37	50	60	85	55	70	80 ma
DC Grid Voltage.....	-1000	-500	-450	-375	-1000	-300	-275	-250 Volts
Peak RF Grid Voltage.....		790	780	735		555	565	560 Volts
Plate Dissipation.....	250	225	225	225	250	225	225	210 Watts
Plate Input.....	1125	1125	975	750	1125	1125	1000	750 Watts

RADIO FREQUENCY POWER AMPLIFIER* CLASS "C" PLATE MODULATED

	L				H			
	Maximum Rating Per Tube	Typical Operation, 1 Tube			Maximum Rating Per Tube	Typical Operation, 1 Tube		
Power Output.....		760	560	440	760	575	450	Watts
Driving Power.....		30	32	33	28	33	31	Watts
DC Plate Voltage.....	4000	3500	2500	2000	4000	3500	2500	2000 Volts
DC Plate Current.....	300	270	300	300	300	270	300	300 ma
DC Grid Current.....	60	45	50	55	85	60	70	70 ma
DC Grid Voltage.....	-1000	-450	-400	-350	-1000	-275	-250	-225 Volts
Peak RF Grid Voltage.....		730	710	660		525	515	490 Volts
Plate Dissipation.....	210	190	190	160	210	190	175	150 Watts
Plate Input.....	950	950	750	600	950	950	750	600 Watts

*Carrier Conditions for 100% modulation peaks and 60% average value.

Gammatron Tubes

AUDIO FREQUENCY POWER AMPLIFIER*

CLASS "B"

	Maximum Rating 2 Tubes	L			H		
		Typical Operation, 2 Tubes			Typical Operation, 2 Tubes		
Power Output.....		1020	960	800	1020	960	900 Watts
Driving Power**.....		70	85	80	45	75	90 Watts
DC Plate Voltage.....	4000	3500	2500	2000	3500	2500	2000 Volts
DC Plate Current, Zero Signal.....		60	90	100	60	90	100 ma
DC Plate Current, Max. Signal.....	750	410	550	640	410	550	660 ma
DC Grid Voltage.....		-260	-165	-125	-110	-75	-50 Volts
Peak RF Grid to Grid Voltage.....		930	850	800	560	590	600 Volts
Plate Input, Max. Signal.....	1500	1435	1375	1280	1435	1375	1320 Watts
Load Resistance Plate to Plate.....		20,000	10,000	6400	20,000	10,000	6400 Ohms

*All data for two tubes.

**Instantaneous power at crest of cycle; effective power is 1/2 of this value.

RADIO FREQUENCY POWER AMPLIFIER*

CLASS "B"

	Maximum Rating Per Tube	L			H		
		Typical Operation, 1 Tube			Typical Operation, 1 Tube		
Power Output.....		125	115	100	130	115	105 Watts
Driving Power**.....		12	20	26	12	20	28 Watts
DC Plate Voltage.....	4000	3000	2000	1500	3000	2000	1500 Volts
DC Plate Current.....	300	115	170	215	120	170	220 ma
DC Grid Current.....		0	1	3	1	4	6 ma
DC Grid Voltage.....		-250	-170	-125	-120	-80	-60 Volts
Peak RF Grid Voltage.....		235	225	225	155	165	175 Volts
Plate Dissipation.....	250	225	225	225	225	225	225 Watts
Plate Input.....	360	350	340	320	360	340	330 Watts

*Carrier Conditions for 100% modulation.

**RF Power at crest of audio cycle.

VERY HIGH FREQUENCY PERFORMANCE L AND H

Frequency	25	50	100	150 mc
Class "C" Unmodulated				
Typical Plate Efficiency, Percent.....	80	78	74	69
Max. Plate Input, Watts.....	1125	1000	860	720
Max. Plate Voltage, Volts.....	5000	4400	3800	3200
Class "C" Modulated				
Typical Plate Efficiency, Percent.....	80	78	74	69
Max. Plate Input, Watts.....	950	850	730	650
Max. Plate Voltage, Volts.....	4000	3600	3100	2750
Class "B" Linear				
Typical Plate Efficiency, Percent.....	35	34	32	30
Max. Plate Input, Watts.....	360	350	340	330
Max. Plate Voltage, Volts.....	4000	3900	3800	3700

Gammatron Tubes

