

GAMMATRON TYPE 354

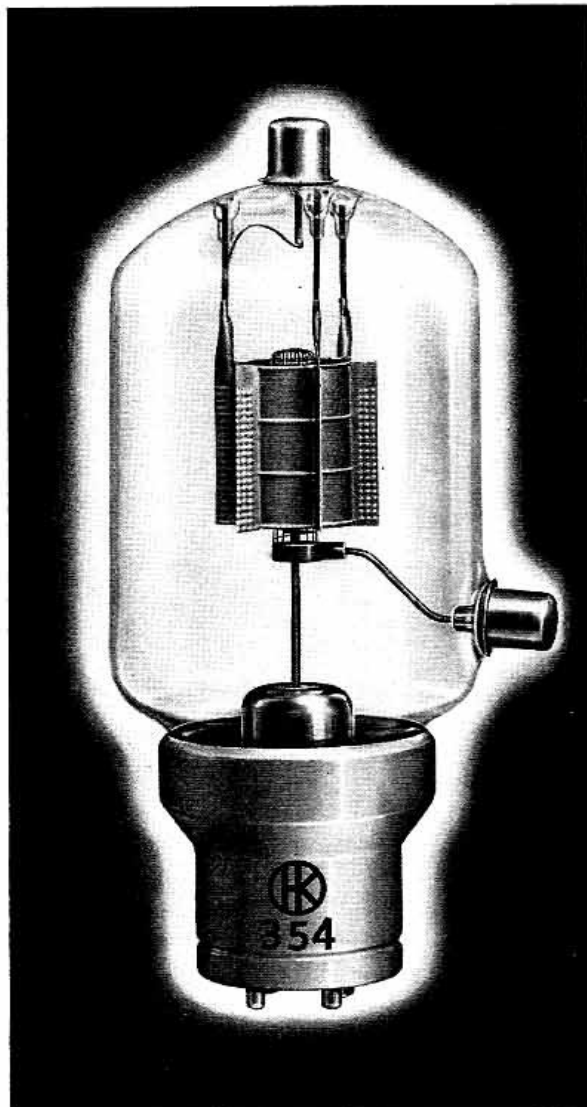

GENERAL PURPOSE TRIODE

150 watt radiation cooled triode, available in two amplification factors: The C a low mu of 14 and the E a high mu of 35. Exceptional HF performance and ability to withstand high voltages.

PHYSICAL DATA

Plate	Cylindrical Tantalum
Grid	Braced Vertical Bar Tantalum
Filament	Thoriated Tungsten
Base	Standard Fifty Watt
Net Weight	8½ Ounces
Shipping Weight	3 Pounds
Maximum Height	9 ³ / ₁₆ Inches
Maximum Diameter	3 ⁷ / ₁₆ Inches

ELECTRICAL DATA

	C	E
Filament Voltage	5.0	5.0 Volts
Filament Current	10	10 Amps.
Normal Plate Dissipation	150	150 Watts
Maximum Plate Input	750	750 Watts
Maximum D.C. Plate Current	300	300 M. A.
Maximum D.C. Plate Voltage	4000	4000 Volts
Maximum D.C. Grid Current	60	85 M. A.
Average Amplification Constant	14	35
Grid-Plate Capacitance	3.3	3.3 Mmfd.
Grid-Filament Capacitance	4.4	4.6 Mmfd.
Plate-Filament Capacitance	0.7	0.5 Mmfd.

The 354 GAMMATRON is a general purpose triode. It has a tantalum plate and grid and embodies the fundamental design features characteristic of GAMMATRON transmitting tubes. Scientific engineering, combined with the highest manufacturing skill, results in a definite superiority over tubes of conventional design.

The plate and grid are mounted on short, direct, low inductance leads. Internal insulators are completely eliminated while perfect alignment is maintained and extremely high interelectrode insulation is permitted. Thus, with the use of tantalum and the elimination of unnecessary internal struc-

ture, it is possible to completely out-gas GAMMATRON tubes without the use of the usual "getter." This excellent vacuum is retained throughout the full life and it is not possible to cause this tube to go soft due to overload. The filament may then be operated in a manner consistent with high thermionic efficiency and long life.

The GAMMATRON method of design results in a tube that is easy to neutralize because of its low interelectrode capacity. It is easy to drive because of its special vertical grid bar design, and it has extremely long life because of its ability to maintain a permanent vacuum of a high degree.

EM 2-46

HEINTZ AND KAUFMAN LTD.

SOUTH SAN FRANCISCO, CALIFORNIA, U - S - A

TYPE 354 GAMMATRON

The information on this and the following page does not represent exact conditions of operation to be imposed for any particular situation. Because tubes are used under many widely different conditions Heintz and Kaufman will gladly furnish information for applications which differ appreciably from the illustrative examples given.

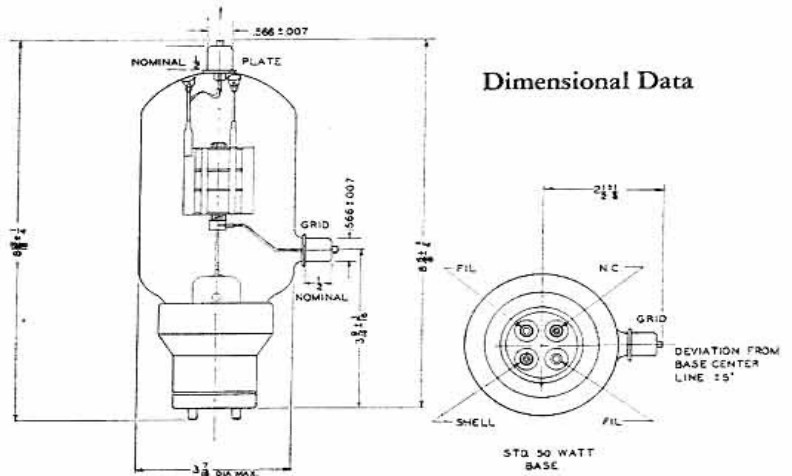

RADIO FREQUENCY POWER AMPLIFIER CLASS "C" UNMODULATED

	C				E			
	Maximum Rating Per Tube	Typical Operation, 1 Tube			Maximum Rating Per Tube	Typical Operation, 1 Tube		
Power Output.....		600	600	450		600	600	450 Watts
Driving Power.....		15	29	31		16	23	28 Watts
DC Plate Voltage.....	4000	4000	3000	2000	4000	4000	3000	2000 Volts
DC Plate Current.....	300	187	250	300	300	185	250	300 ma
DC Grid Current.....	60	30	50	60	75	45	55	65 ma
DC Grid Voltage.....	-1000	-400	-400	-300	-1000	-220	-220	-200 Volts
Peak RF Grid Voltage.....		580	650	570		420	470	475 Volts
Plate Dissipation.....	150	135	150	150	150	150	150	150 Watts
Plate Input.....	750	750	750	600	750	750	750	600 Watts

RADIO FREQUENCY POWER AMPLIFIER* CLASS "C" PLATE MODULATED

	C					E				
	Maximum Rating Per Tube	Typical Operation, 1 Tube				Maximum Rating Per Tube	Typical Operation, 1 Tube			
Power Output.....		505	450	380	275		505	450	375	275 Watts
Driving Power.....		22	25	27	25		25	27	32	32 Watts
DC Plate Voltage.....	3000	3000	2500	2000	1500	3000	3000	2500	2000	2000 Volts
DC Plate Current.....	250	210	230	250	250	250	210	230	250	250 ma
DC Grid Current.....	60	50	55	60	60	75	50	55	60	60 ma
DC Grid Voltage.....	-1000	-300	-300	-275	-225	-1000	-325	-325	-350	-350 Volts
Peak RF Grid Voltage.....		500	515	505	455		560	575	625	625 Volts
Plate Dissipation.....	127	125	125	120	100	127	125	125	125	125 Watts
Plate Input.....	635	630	575	500	375	635	630	575	500	500 Watts

*Carrier Conditions for 100% modulation peaks and 60% average value.

Gammatron Tubes

AUDIO FREQUENCY POWER AMPLIFIER*

CLASS "B"

	Maximum Rating 2 Tubes	C			E		
		Typical Operation, 2 Tubes			Typical Operation, 2 Tubes		
Power Output.....		810	700	660	810	700	660 Watts
Driving Power**.....		55	50	60	45	50	60 Watts
DC Plate Voltage.....	4000	3000	2500	2000	3000	2500	2000 Volts
DC Plate Current, Zero Signal.....		50	60	70	50	60	70 ma
DC Plate Current, Max. Signal.....	600	370	400	480	370	400	480 ma
DC Grid Voltage.....		-220	-175	-140	-70	-50	-35 Volts
Peak AF Grid to Grid Voltage.....		740	630	640	470	460	470 Volts
Plate Input, Max. Signal.....	1125	1110	1000	960	1110	1000	960 Watts
Load Resistance Plate to Plate.....		19200	14400	9300	19200	14400	9300 Ohms

*All data for two tubes.

**Instantaneous power at crest of cycle; effective power is 1/2 of this value.

RADIO FREQUENCY POWER AMPLIFIER*

CLASS "B"

	Maximum Rating Per Tube	C			E		
		Typical Operation, 1 Tube			Typical Operation, 1 Tube		
Power Output.....		90	75	60	90	75	60 Watts
Driving Power**.....		6	10	28	5	11	30 Watts
DC Plate Voltage.....	3000	3000	2000	1000	3000	2000	1000 Volts
DC Plate Current.....	250	80	112	210	80	112	210 ma
DC Grid Current.....		0	0	10	1	5	18 ma
DC Grid Voltage.....		-250	-150	-75	-75	-50	-25 Volts
Peak RF Grid Voltage.....		195	160	180	112	120	157 Volts
Plate Dissipation.....	150	150	150	150	150	150	150 Watts
Plate Input.....	240	240	225	210	240	225	210 Watts

*Carrier Conditions for 100% modulation.

**RF Power at crest of audio cycle.

HIGH FREQUENCY PERFORMANCE C AND E

Frequency	15	25	35	mc
Class C Unmodulated				
Max. Input.....	600	555	450	Watts
Max. Plate Volts.....	3200	3000	2400	Volts
Typical Plate Efficiency.....	75	73	67	Pct.
Class C Modulated				
Max. Input.....	510	470	380	Watts
Max. Plate Volts.....	2500	2400	2000	Volts
Class B Linear				
Max. Input.....	225	220	215	Watts
Max. Plate Volts.....	3200	3000	2400	Volts

Gammatron Tubes

