

GAMMATRON TYPE 257

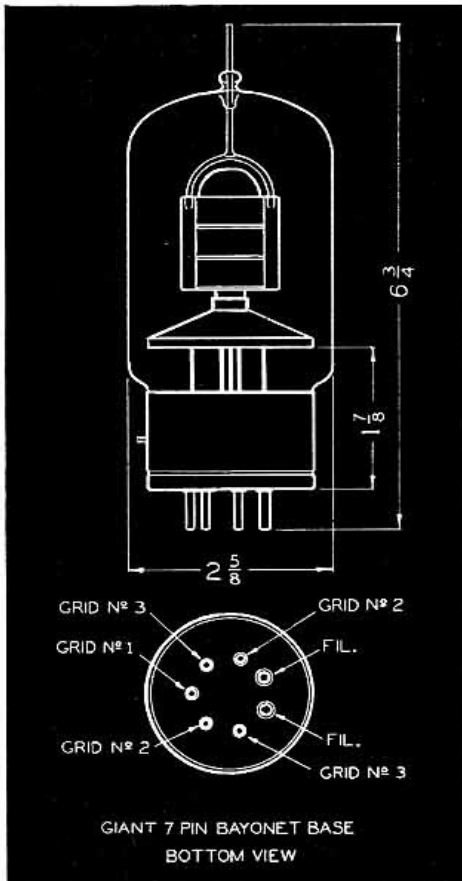

BEAM PENTODE

ELECTRICAL DATA

Plate Dissipation	75 Watts
Maximum Screen Input	25 Watts
Filament Voltage	5.0 Volts
Filament Current	7.5 Amps.

INTERELECTRODE CAPACITIES

Plate-Grid Capacity	0.04 Mmfd.
Input Capacity	13.8 Mmfd.
Output Capacity	6.7 Mmfd.

PHYSICAL DATA

Plate	Enclosed Cylindrical Tantalum
Grids	Vertical Bar Tantalum
Filament	Thoriated Tungsten
Base	Giant 7-pin Bayonet
Envelope	Nonex Glass
Net Weight	6 Ounces
Shipping Weight	1 Pound
Maximum Height	6 7/8 Inches
Maximum Diameter	2 5/8 Inches

All parts rigidly welded. No guide holes, springs or internal insulators.

MAXIMUM RATINGS AND TYPICAL OPERATING CONDITIONS

RADIO FREQUENCY POWER AMPLIFIER CLASS "C" UNMODULATED

	Maximum Rating per Tube	TYPICAL OPERATION, 1 TUBE*					
		230	230	225	170	110	
Power Output		230	230	225	170	110	Watts
Driving Power		1.4	2.1	1.9	1.4	2.4	Watts
D.C. Plate Volts	2000	2000	2000	2000	1500	1000	Volts
D.C. Plate Current	150	150	150	150	150	150	M. A.
D.C. Suppressor Voltage		60	60	0	60	60	Volts
D.C. Suppressor Current		4	5	0	4	6	M. A.
D.C. Screen Voltage	500	500	400	500	500	400	Volts
D.C. Screen Current	50	11	14	25	11	20	M. A.
D.C. Control Grid Voltage	-500	-200	-180	-290	-200	-180	Volts
D.C. Control Grid Current	25	6	9	8	6	10	M. A.
Peak R.F. Control Voltage		255	260	270	255	270	Volts
Plate Dissipation	75	70	70	75	55	40	Watts

*Other values to obtain similar results may be used provided the maximum ratings are not exceeded.

SOUTH SAN FRANCISCO

HEINTZ AND



KAUFMAN

LTD.

CALIFORNIA U.S.A.

RADIO FREQUENCY POWER AMPLIFIER— CLASS "C" PLATE MODULATED

(100% Modulation Peaks, 60% Average Value)

	Maximum Rating per Tube	1 Tube Carrier Conditions			
		143	115	95	Watts
Power Output	178	143	115	95	Watts
Driving Power	1.7	1.7	1.7	1.7	Watts
D.C. Plate Volts	1800	1800	1500	1250	1000 Volts
D.C. Plate Current	135	135	135	135	135 M. A.
D.C. Suppressor Volts	60	60	60	60	60 Volts
D.C. Suppressor Current	4	4	4	4	5 M. A.
D.C. Screen Volts	400	400	400	400	400 Volts
D.C. Screen Current	40	11	11	11	13 M. A.
D.C. Control Grid Volts	-500	-130	-130	-130	-130 Volts
D.C. Control Grid Current	25	8	8	8	8 M. A.
Peak R.F. Control Voltage	235	235	235	235	235 Volts
Plate Dissipation	65	65	60	54	40 Watts

RADIO FREQUENCY DOUBLER AMPLIFIER MAXIMUM INPUT 200 WATTS

	Maximum Rating per Tube	Typical Operation			
		120	110	80	
Power Output		120	110	80	Watts
Driving Power		.7	1.8	5.5	Watts
D.C. Plate Voltage	2000	2000	1500	1000	Volts
D.C. Plate Current	150	95	120	150	M. A.
D.C. Suppressor Voltage		60	60	60	Volts
D.C. Suppressor Current		2	4	6	M. A.
D.C. Screen Voltage	500	500	500	500	Volts
D.C. Screen Current	50	6	13	25	M. A.
D.C. Control Grid Voltage	-500	-300	-330	-400	Volts
D.C. Control Grid Current	25	2	5	12	M. A.
Peak R.F. Control Voltage		340	400	510	Volts
Plate Dissipation	75	70	70	70	Watts

RADIO FREQUENCY POWER AMPLIFIER— CLASS "C" SUPPRESSOR GRID MODULATED

(Maximum Input Watts 110)

	Maximum Rating per Tube	Typical Carrier Conditions			
		35	33	32	
Power Output		35	33	32	Watts
Driving Power		.4	1.4	2.0	Watts
Audio Power		100*	100*	500†	Milliwatts
D.C. Plate Voltage	2000	2000	1500	1000	Volts
D.C. Plate Current	100	55	70	90	M. A.
D.C. Suppressor Voltage	-500	-300	-210	-135	Volts
Peak Suppressor Current		0	0	3	M. A.
D.C. Screen Voltage‡		500	500	600	Volts
D.C. Screen Current		27	44	41	M. A.
Screen Dropping Resistor		2000	2000	5000	Ohms
D. C. Control Grid Voltage	-500	-130	-130	-130	Volts
D. C. Control Grid Current	25	3	8	11	M. A.
Peak R.F. Driving Voltage		150	195	200	Volts
Peak A. F. Modulating Voltage		300	210	175	Volts
Plate Dissipation	75	75	72	60	Watts

*Use Type 6C5 tube or equal with 1:2 step-up transformer ratio.

†Use receiving type pentode as 6F6 and 1:1 transformer ratio.

‡Applied through the indicated screen dropping resistor.

CLASS "A" AMPLIFIER—AUDIO AND TELEVISION—MAXIMUM INPUT 75 WATTS

	Maximum Rating per Tube	Typical Operation		
		34	30	
Power Output		34	30	Watts
D.C. Plate Voltage	2000	1000	500	Volts
D.C. Plate Current	150	75	150	M. A.
D.C. Suppressor Voltage		0	0	Volts
D.C. Screen Voltage	500	300	500	Volts
D.C. Screen Current	40	5	10	M. A.
D.C. Control Grid Voltage	-500	-27	-47	Volts
Peak Audio Signal Voltage		27	47	Volts
Plate Dissipation	75	75	75	Watts
Plate Load, Ohms		12000	2600	Ohms

TYPE 257 BEAM PENTODE OPERATING NOTES

- Protect your investment: Always provide sufficient fixed bias or cathode bias to limit the plate current to a safe value. Plate current depends on the screen voltage not the plate voltage, and the tube may be easily damaged by loss of bias since at zero bias the plate current is great with proper screen voltage. Apply reduced plate and screen voltages when tuning up transmitter.
- The 257 has a very high transconductance and hence extreme care must be taken to prevent self-oscillation. The output and input circuits must be completely separated. The internal shield should be matched with an external one with about $\frac{1}{8}$ inch clearance to the glass envelope. Parasitic suppressors are often helpful. Screen and suppressor leads should be by-passed directly at the socket. For operation on high frequencies both parallel screen and suppressor leads should be by-passed to the filament.
- In employing various combinations of plate and screen voltages, the following general rules will be helpful:
 - Driving requirements and screen current lower as screen voltage is increased.
 - Driving requirements lower and screen current is decreased with approximately 60 volts applied to the suppressor.
 - For the majority of applications zero suppressor voltage will be satisfactory.
- Apply screen voltage or excitation after plate voltage or at the same time, *not before*. Remove screen voltage or excitation before plate voltage or at same time.
- In tuning the tank coil to resonance there will be little change in plate current when the amplifier is loaded. Use the tantalum plate as a resonance indicator. Minimum plate temperature indicates resonance.

ULTRA HIGH FREQUENCY RATINGS

Percentage maximum plate voltage and input power based on low frequency ratings shown above.

Frequency	75	120	150 Mc.
Class "B" or Grid Modulated R. F. P. A.....	100%	90%	80%
Class "C" R. F. P. A. Telegraph or Telephone.....	100%	75%	50%



GAMMATRON

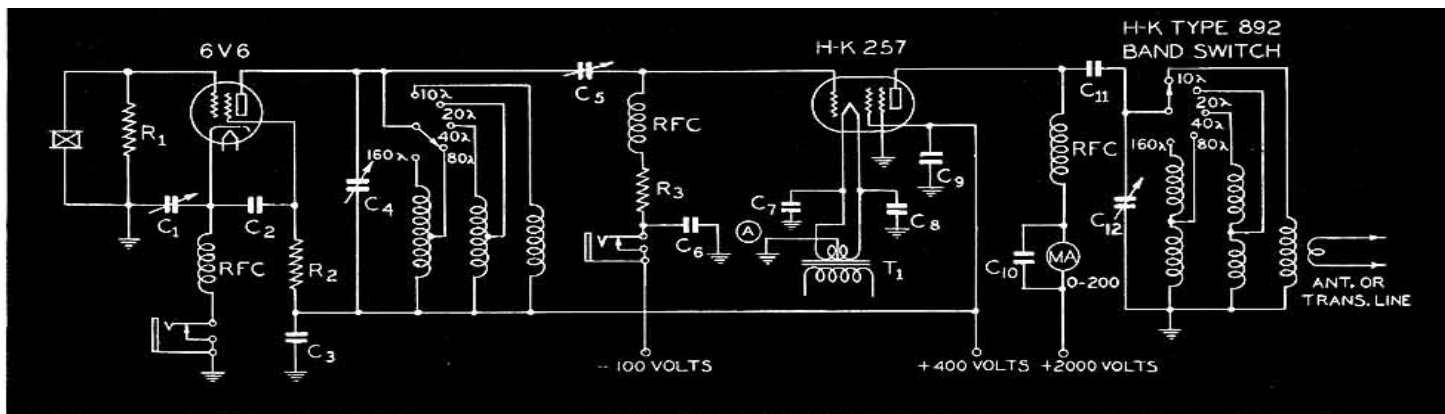

HK-257 ALL-BAND TRANSMITTER

The Type 257 beam pentode is particularly adapted for an all-band radio transmitter, since it requires extremely low driving power and does not require neutralization. Such a transmitter is shown in the above wiring diagram. It is capable of operation in all of the amateur bands from 10 to 160 meters. It incorporates band switching in the crystal oscillator and radio frequency amplifier circuit. The new heavy duty H&K Band Switch is employed in the final amplifier and any of the low power all-band coil assemblies may be employed in the oscillator plate circuit.

The Type 257 beam pentode requires only a small amount of radio frequency excitation and hence a single 6V6 metal tube in the oscillator circuit will drive the radio frequency amplifier to its full output. The careful internal shielding of the 257 provides that no neutralization is necessary. Excellent shielding between the grid circuit of the final amplifier and the output circuit is obtained by mounting the 257 part way below the transmitter chassis in such a manner that the internal shield flange of the tube is flushed with the chassis deck.

The 257 has a tantalum plate which makes an excellent tuning indicator. Since maximum antenna output always occurs at the point of minimum plate color, this form of tuning is more convenient and more accurate than the indication of a milliammeter in the plate or cathode circuit. The current dip is rather small at the point of resonance in a pentode tube when proper load is coupled into the tank circuit.

MODULATION

If desired, this radio frequency unit may be adapted to telephone purposes by applying a number of forms of modulation. The tube may be plate modulated, suppressor grid modulated, or cathode modulated in accordance with the particular requirements. Details for the first two forms of modulation are found elsewhere in this data sheet. For cathode modulation a pair of Type 6L6 tubes in push-pull connection will supply more than sufficient modulating power. The cathode impedance of the Type 257 pentode for this type of modulation is approximately 1000 ohms and for use with Type 6L6 tubes the plate-to-plate impedance of 6000 ohms on the primary of the modulation transformer will give a good match. The plate current to the Type 257 beam pentode should be, for this condition of operation, 80 to 100 milliamperes, and the grid current should be approximately 5 milliamperes. For complete data on cathode modulation and other HK equipped transmitters refer to Frank C. Jones' book, "Cathode Modulation."

The cathode modulation is applied at the point marked (A) on the wiring diagram and the fixed bias on the tube of 100 volts, which is necessary for good modulation, may be obtained through a voltage regulator tube, such as the Type VR-105.

CRYSTAL OSCILLATOR

The Type 6V6 oscillator employs a radio frequency choke in its cathode circuit, together with an adjustable condenser for controlling the amount of regeneration in this circuit. This condenser must be set to a value that allows the plate circuit to be tuned to the second harmonic of 80 and 160 meter crystals. For 10 and 20 meter operation, crystals of these respective frequencies should be employed. A cathode regenerative circuit is a distinct aid in obtaining good output from 10 to 20 meter crystals.

In employing standard band switching coil units with the oscillator, it will probably be necessary to remove a few turns from the 10 meter coil in order to resonate the circuit over the entire band.

COIL DATA

The final tank coils are wound on ceramic forms. A ten meter coil has $4\frac{1}{2}$ turns of #10 wire wound on a $1\frac{1}{8}$ " ceramic form. The length of the winding is approximately $1\frac{1}{4}$ ". The 20 and 40 meter coils are wound on $2\frac{1}{2}$ " diameter ceramic forms. Five turns for the 20 meter coil and nine additional turns for the 40 meter coil. The nine turn winding is spaced approximately 1" from the five turn winding and the two windings are connected in series to give a coil of 14 turns to the 40 meter operation. The 80 and 160 meter coils are wound in a similar manner on a 3" diameter ceramic form. The 80 meter section of the coil has $12\frac{1}{2}$ turns and the 160 meter has a total of $28\frac{1}{2}$ turns. A ribbed coil form may be employed such that approximately 7 turns per inch of #12 enameled wire may be employed. The 20 and 40 meter coil is wound on the same size wire employing six turns per inch. All of these coils should be grouped around the Type 257 pentode with the high frequency coil mounted close to the H-K Band Switch. If operation on 160 meters is not contemplated, a final tank condenser of approximately 100 to 125 micro-microfarads should be employed in place of the 250 micro-microfarad unit.

OPERATION

Antenna may be coupled to the tuned plate circuit by link coupling to the external tuned antenna circuit or by inductive coupling with a few turns in wire wound directly over the coil form. The Type 257 will require a plate voltage of 1500 to 2000 volts, while 400 volts should be supplied for the Type 6V6 tube and this voltage may be also applied to the screen of the Type 257 beam pentode.

Since the tuning of the Type 257 beam pentode is somewhat unconventional compared to that of a neutralized triode amplifier, it is desirable to provide some means of indicating the amount of antenna or feeder current at all times, although the degree of plate color and amount of input to the tube always gives a good indication of the operating efficiency.

COMPONENTS

- R₁—100,000 Ohm, 1 Watt resistor.
- R₂—15,000 Ohm, 10 Watt resistor.
- R₃—5,000 Ohm, 10 Watt resistor.
- C₁—350 mmf. variable mica condenser.
- C₂—.005 mf. 500 Volt condenser.
- C₃—.01 mf. 500 Volt condenser.
- C₄—140 mmf. variable air condenser.
- C₅—100 mmf. variable air condenser.
- C₆—1.0 mf. paper condenser.
- C₇, C₈—.003 mf. mica condenser.
- C₉—.01 mf. 500 Volt mica condenser.
- C₁₀—.01 mf. mica condenser.
- C₁₁—.002 mf. 5000 Volt mica condenser.
- C₁₂—250 mmf. 3000 Volt variable air condenser.
- T₁—5.0 Volt 7.5 Amp. filament transformer.

GAMMATRON

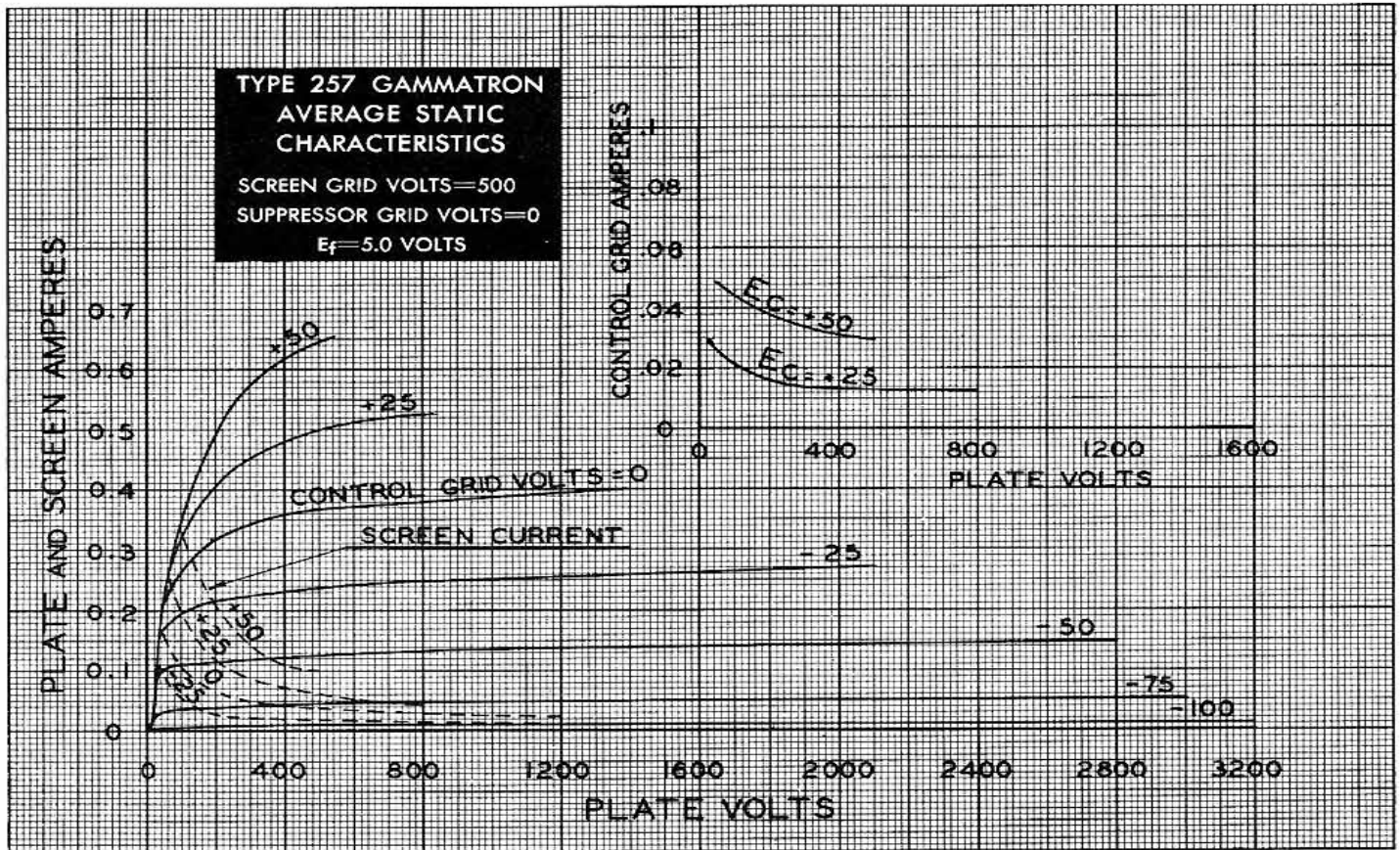
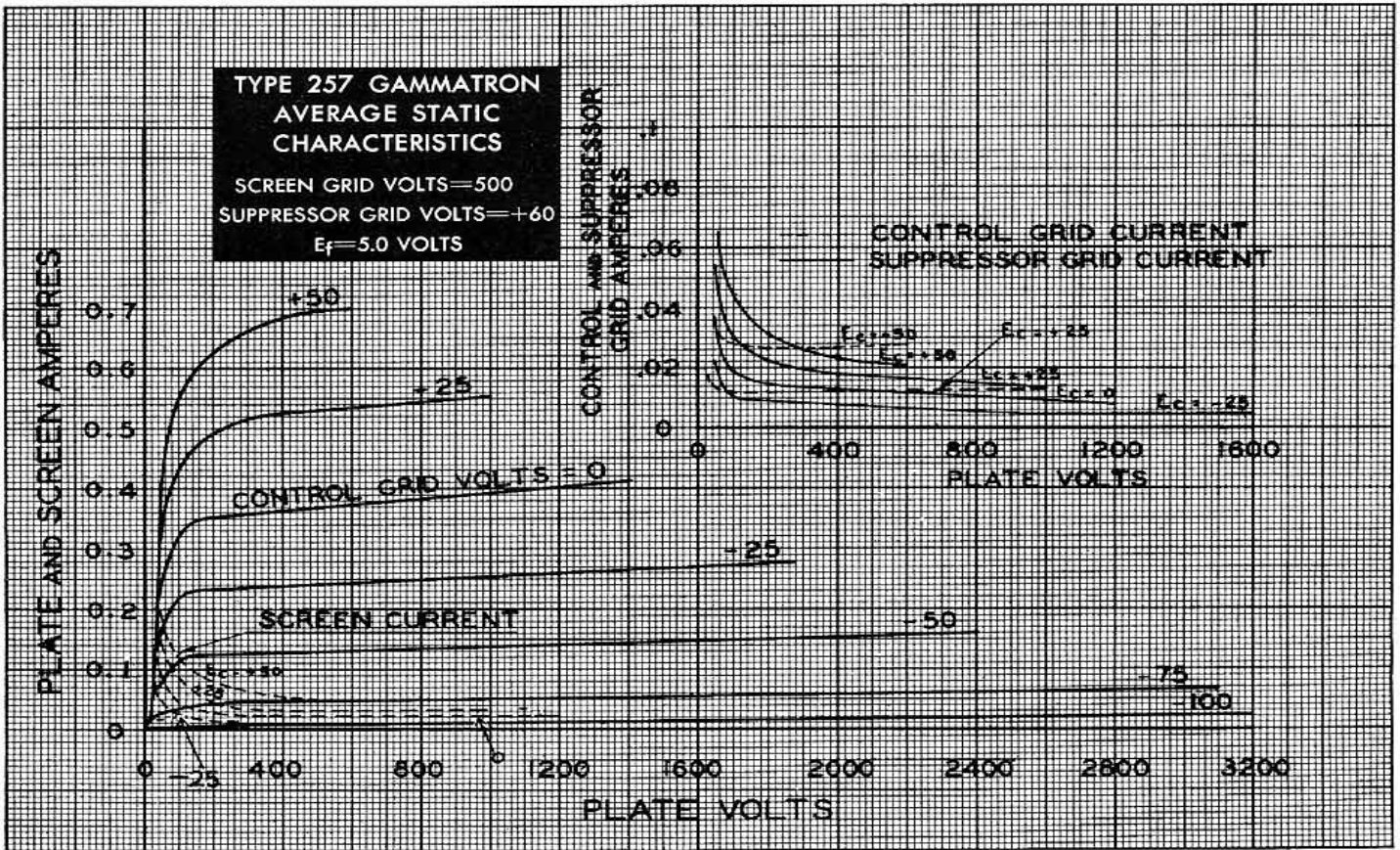

 **GAMMATRON**