



EIMAC

A Division of Varian Associates
SAN CARLOS, CALIFORNIA

4CX1500B
RADIAL BEAM
POWER TETRODE
JEDEC DESIGNATION
8660

The Eimac 4CX1500B is ceramic and metal, forced-air cooled, radial beam tetrode with a rated maximum plate dissipation of 1500 watts. It is a low-voltage, high-current tube specifically designed for exceptionally low intermodulation distortion and low grid interception. The low distortion characteristics make the 4CX1500B especially suitable for radio-frequency and audio-frequency linear amplifier service.



ELECTRICAL

GENERAL CHARACTERISTICS

	<u>Min.</u>	<u>Nom.</u>	<u>Max.</u>	
Cathode: Oxide Coated, Unipotential				
Heating Time - - -	3			minutes
Heater: Voltage - - - -		6.0		volts
Current - - - -	8.1		9.9	amperes

Transconductance:
($I_{p1}=0.5$ amperes, $E_{c2}=225$ volts) 30,000 umhos

Direct Interelectrode Capacitances, Grounded Cathode: *				<u>Min.</u>	<u>Nom.</u>	<u>Max.</u>	
Input - - - - -	-	-	-	77		90	μmf
Output - - - - -	-	-	-	11		13	μmf
Feedback - - - - -	-	-	-			0.022	μmf

Direct Interelectrode Capacitances, Grounded Grid and Screen: *							
Input - - - - -	-	-	-	35		41	μmf
Output - - - - -	-	-	-	11		13	μmf
Feedback - - - - -	-	-	-			0.005	μmf

*In Shielded Fixture

MECHANICAL

Base - - - - -	-	-	-	-	-	-	-	Special, breechblock terminal surfaces
Maximum Operating Temperatures:								
Ceramic-to-Metal Seals - - - - -	-	-	-	-	-	-	-	250°C
Anode Core - - - - -	-	-	-	-	-	-	-	250°C
Recommended Socket - - - - -	-	-	-	-	-	-	-	Eimac SK-800 Series
Operating Position - - - - -	-	-	-	-	-	-	-	Any
Maximum Over-All Dimensions:								
Height - - - - -	-	-	-	-	-	-	-	4.8 inches
Diameter - - - - -	-	-	-	-	-	-	-	3.37 inches
Net Weight - - - - -	-	-	-	-	-	-	-	27 ounces
Shipping Weight (Approximate) - - - - -	-	-	-	-	-	-	-	3 pounds

RADIO-FREQUENCY LINEAR AMPLIFIER

Class AB

MAXIMUM RATINGS

DC PLATE VOLTAGE - - -	3000 MAX. VOLTS
DC SCREEN VOLTAGE - - -	400 MAX. VOLTS
DC PLATE CURRENT - - -	.900 MAX. AMP
PLATE DISSIPATION - - -	1500 MAX. WATTS
SCREEN DISSIPATION - - -	12 MAX. WATTS
CONTROL GRID DISSIPATION - - -	1 MAX. WATTS

*Adjust to the specified Zero-Signal Plate Current.

**The driving power specified includes the power dissipated in a 1000 ohm swamping resistor between the control grid and the cathode.

***The intermodulation distortion products will be as specified or better for all levels from zero-signal to maximum output power and are referenced against one tone of a two equal tone signal.

TYPICAL OPERATION (Frequencies below 30 MHz)

Class AB₂, Grid Driven, Peak Envelope or Modulation Crest Conditions

DC Plate Voltage - - -	2500	2750	2900	Volts
DC Screen Voltage - - -	225	225	225	Volts
DC Grid Voltage* - - -	-34	-34	-34	Volts
Zero-Signal DC Plate Current - - -	300	300	300	mA
Single-Tone DC Plate Current - - -	720	755	710	mA
Two-Tone DC Plate Current - - -	530	555	542	mA
Single-Tone DC Grid Current - - -	1.3	0.95	0.53	mA
Two-Tone DC Grid Current - - -	0.06	0.20	0.06	mA
Single-Tone DC Screen Current - - -	-7	-14	-15	mA
Two-Tone DC Screen Current - - -	-11	-11	-11	mA
Peak RF Grid Voltage - - -	46	45	41	Volts
Driving Power** - - -	1.5	1.5	1.5	Watts
Useful Output Power - - -	900	1100	1100	Watts
Resonant Load Impedance - - -	1900	1900	2200	Ohms
Intermodulation Distortion Products*** - - -				
3rd order - - -	-38	-40	-43	db
5th order - - -	-47	-48	-47	db



AUDIO AMPLIFIER OR MODULATOR

Class AB₁

MAXIMUM RATINGS

DC PLATE VOLTAGE	- - -	3000 MAX. VOLTS
DC SCREEN VOLTAGE	- - -	400 MAX. VOLTS
DC PLATE CURRENT	- - -	.900 MAX. AMP
PLATE DISSIPATION	- - -	1500 MAX. WATTS
SCREEN DISSIPATION	- - -	12 MAX. WATTS
GRID DISSIPATION	- - -	1.0 MAX. WATTS

*Approximate values.
**Adjust grid bias to obtain listed zero-signal plate current.

TYPICAL OPERATION (Sinusoidal wave, 2 tubes unless noted)

DC Plate Voltage	- - -	2000	2500	2900	Volts
DC Screen Voltage	- - -	325	325	325	Volts
DC Grid Voltage**	- - -	-60	-60	-60	Volts
Zero-Signal DC Plate Current	- - -	500	500	500	mA
Max.-Signal DC Plate Current	- - -	1.68	1.69	1.69	Amps
Zero-Signal DC Screen Current*	- - -	-30	-25	-20	mA
Max.-Signal DC Screen Current*	- - -	-27	-33	-32	mA
Effective Load, Plate to Plate	- - -	1948	2715	3333	Ohms
Driving Power	- - -	0	0	0	Watts
Max.-Signal Plate Output Power	- - -	1604	2258	2774	Watts

NOTE: "TYPICAL OPERATION" data are obtained by calculation from the published characteristic curves and confirmed by direct tests. Adjustment of the grid bias to obtain the specified zero-signal plate current is assumed. When grid drive is applied, the screen voltage required to obtain the specified value of plate current without drawing grid current may vary somewhat from the typical values shown.

APPLICATION

Cooling — The maximum temperature rating for the anode core of the 4CX1500B is 250°C. Sufficient forced air circulation must be provided to keep the temperature of the anode at the base of the cooling fins and the temperature of the ceramic-to-metal seals to below 250°C. Air flow requirements to maintain seal temperature at 225°C in 50°C ambient air are tabulated below (for operation below 30 megahertz). Tube mounted in recommended socket and chimney.

Plate Dissipation watts	Sea Level		6000 Feet	
	Air Flow CFM	Pressure Drop inches water	Air Flow CFM	Pressure Drop inches water
1000	22	.20	26	.25
1500	39	.50	49	.63

*Since the power dissipated by the heater represents about 60 watts and since grid plus screen dissipation can, under some conditions, represent another 13 watts, allowance has been made in preparing this tabulation for an additional 73 watts dissipation.

The blower selected in a given application must be capable of supplying the desired air flow at a back pressure equal to the pressure drop shown above plus any drop encountered in ducts and filters.

At other altitudes and ambient temperatures the flow rate must be modified to obtain equivalent cooling. The flow rate and corresponding pressure differential must be determined individually in such cases, using rated maximum temperatures as the criteria for satisfactory cooling.

Heater — The rated heater voltage for the 4CX1500B is 6.0 volts. The voltage, as measured at the socket, should be maintained at this value to minimize variations in operation and to obtain maximum tube life. In no case should the voltage be allowed to exceed 5% above or below the rated value.

The cathode and one side of the heater are internally connected.

It is recommended that the heater voltage be applied for a period of not less than 3 minutes before other operating voltages are applied. From an initial cold condition, tube operation will stabilize after a period of approximately 5 minutes.

Intermodulation Distortion — The Radio Frequency Linear Amplifier operating conditions including the distortion data are the results of actual operation in a neutralized grid-driven amplifier. Plots of IM distortion versus power output under two-tone conditions, as a function of zero-signal plate current, are included to illustrate the effect of this parameter upon distortion. Because the 4CX1500B has very low grid interception it is possible to drive the grid positive without any adverse effects upon the distortion level or upon the driver. Class AB₂ linear amplifier operation is therefore possible and recommended. It is also recommended that a low impedance driver be used and that the input of the 4CX1500B be swamped with a 1000 ohm resistor from grid to cathode so as to provide an almost constant load to the driver.

Control-Grid Operation — The control grid dissipation rating of the 4CX1500B is 1 watt. The design features which make the 4CX1500B such an extremely linear tube also contribute to very low grid interception. It will be found that the grid will be driven into the positive grid region in the typical operation of the tube. The grid current will usually be less than 1.0 milliamperere.

Screen-Grid Operation — Tetrode tubes may exhibit reversed screen current to a greater or lesser degree depending on individual tube design. This characteristic is prominent in the 4CX1500B and, under some operating conditions, indicated negative screen currents in the order of 35 milliamperes may be encountered.

The maximum rated power dissipation for the screen grid in the 4CX1500B is 12 watts and

the screen power should be kept below this level. The product of the peak screen voltage and the indicated dc screen current approximates the screen input power except when the screen current indication is near zero or negative. In the usual tetrode amplifier, where no signal voltage appears between cathode and screen, the peak screen voltage is equal to the dc screen voltage. Experience has shown that the screen will operate within the limits established for this tube if the indicated screen current, plate voltage and drive voltage approximate the "Typical Operation" values.

The screen supply voltage must be maintained constant for any values of negative and positive screen currents that may be encountered. Dangerously high plate currents may flow if the screen power supply exhibits a rising voltage characteristic with negative screen current. Stabilization may be accomplished in several different ways. A bleeder resistor may be connected from screen to cathode; a combination of VR tubes may be connected from screen to cathode; or an electron-tube regulator circuit may be used in the screen supply. It is absolutely essential to use a bleeder if a series electron-tube regulator is employed. The screen bleeder current should approximate 70 milliamperes to

adequately stabilize the screen voltage. It should be observed that this bleeder power may be usefully employed to energize low-power stages of the transmitter.

Pulse Operation — The maximum rated plate dissipation power is 1500 watts. Except for brief periods during circuit adjustments, this maximum value should not be exceeded.

The top cap on the anode cooler may be used as a plate terminal at low frequencies or a circular clamp or spring-finger collet encircling the cylindrical outer surface of the anode cooler may be used at high frequencies.

Points of electrical contact with the anode cooler should be kept clean and free of oxide to minimize radio-frequency losses. The anode cooler should be inspected periodically and cleaned when necessary to remove any dirt which might interfere with effective cooling.

Special Applications — If it is desired to operate this tube under conditions different from those given here, write to the Power Grid Product Manager, EIMAC Division of Varian Associates, San Carlos, California, for information and recommendations.

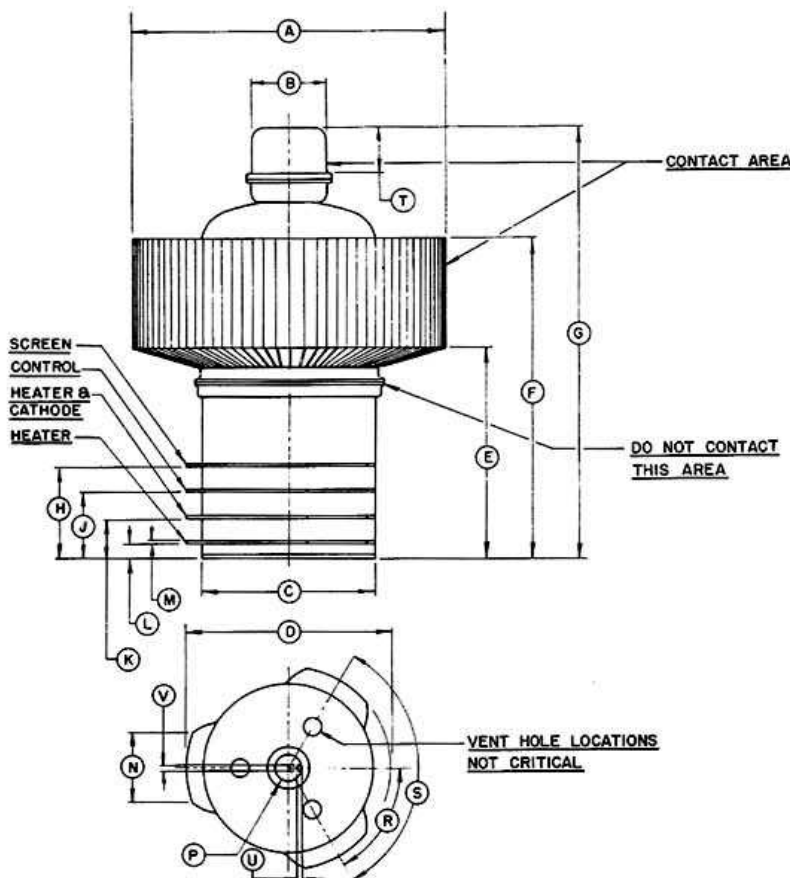

DIMENSION DATA			
REF.	NOM.	MIN.	MAX.
A	3.335	3.365	
B	.807	.817	
C	1.870	1.900	
D	2.250 DIA.	2.300 DIA.	
E	2.195	2.380	
F	3.410	3.550	
G	4.600	4.800	
H	.950	1.000	
J	.675	.725	
K	.400	.450	
L	.140	.170	
M	.020	.030	
N	.700	.800	
P	.314 DIA.	.326 DIA.	
R	55°	65°	
S	115°	125°	
T	.470	.530	
U	.023	.043	
V	.057 DIA.	.073 DIA.	

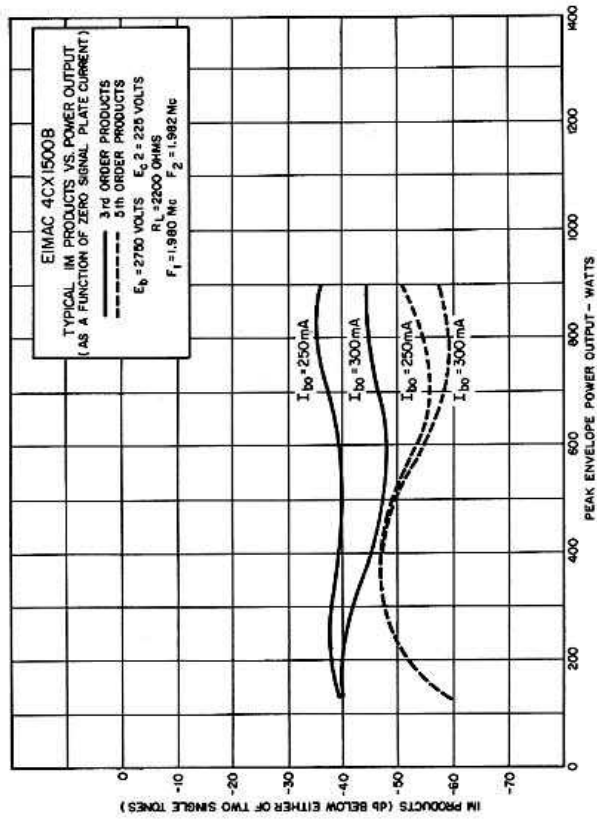
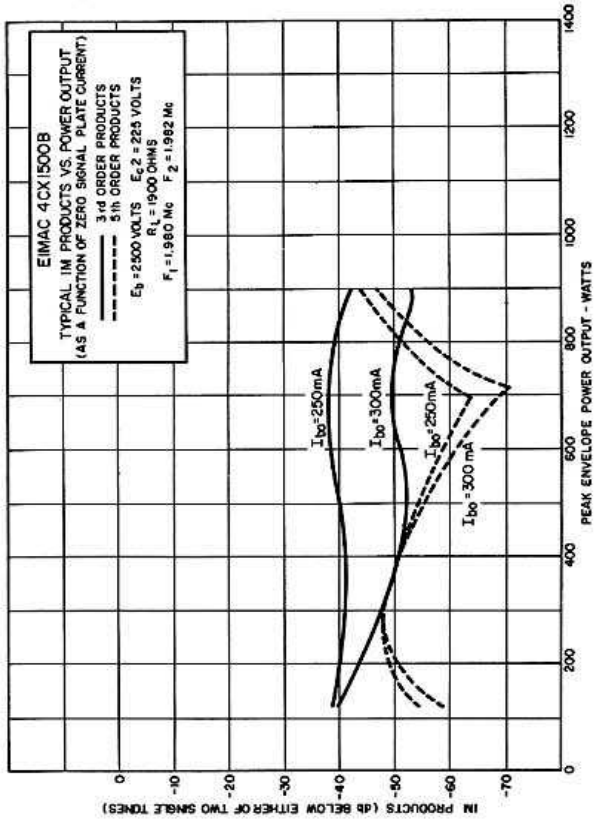
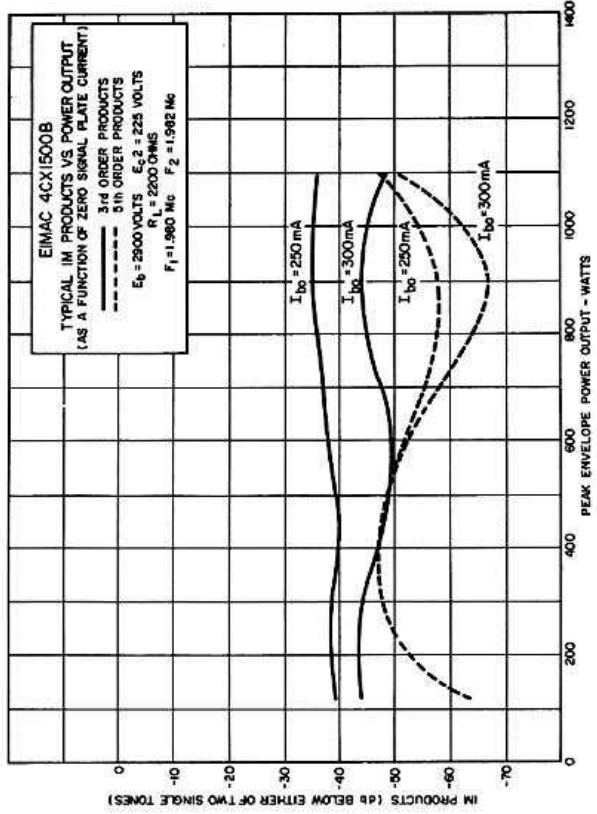
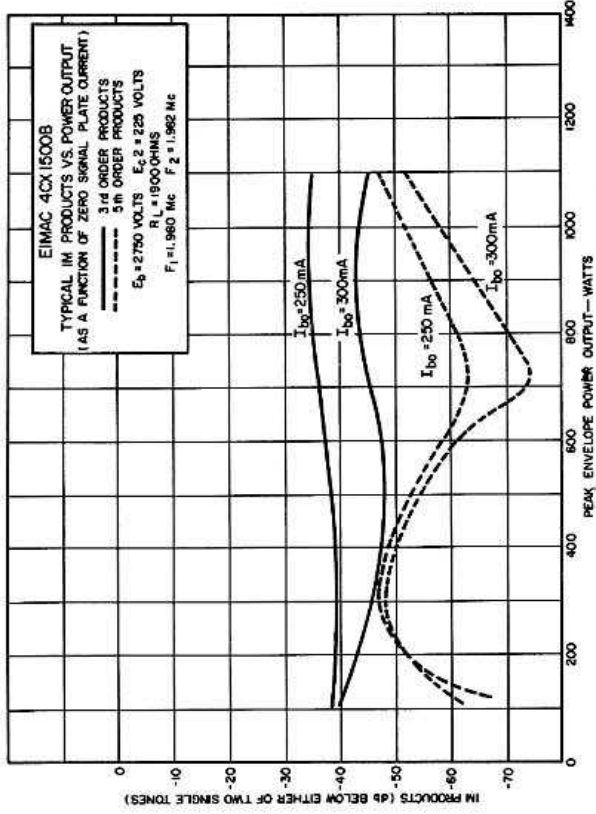

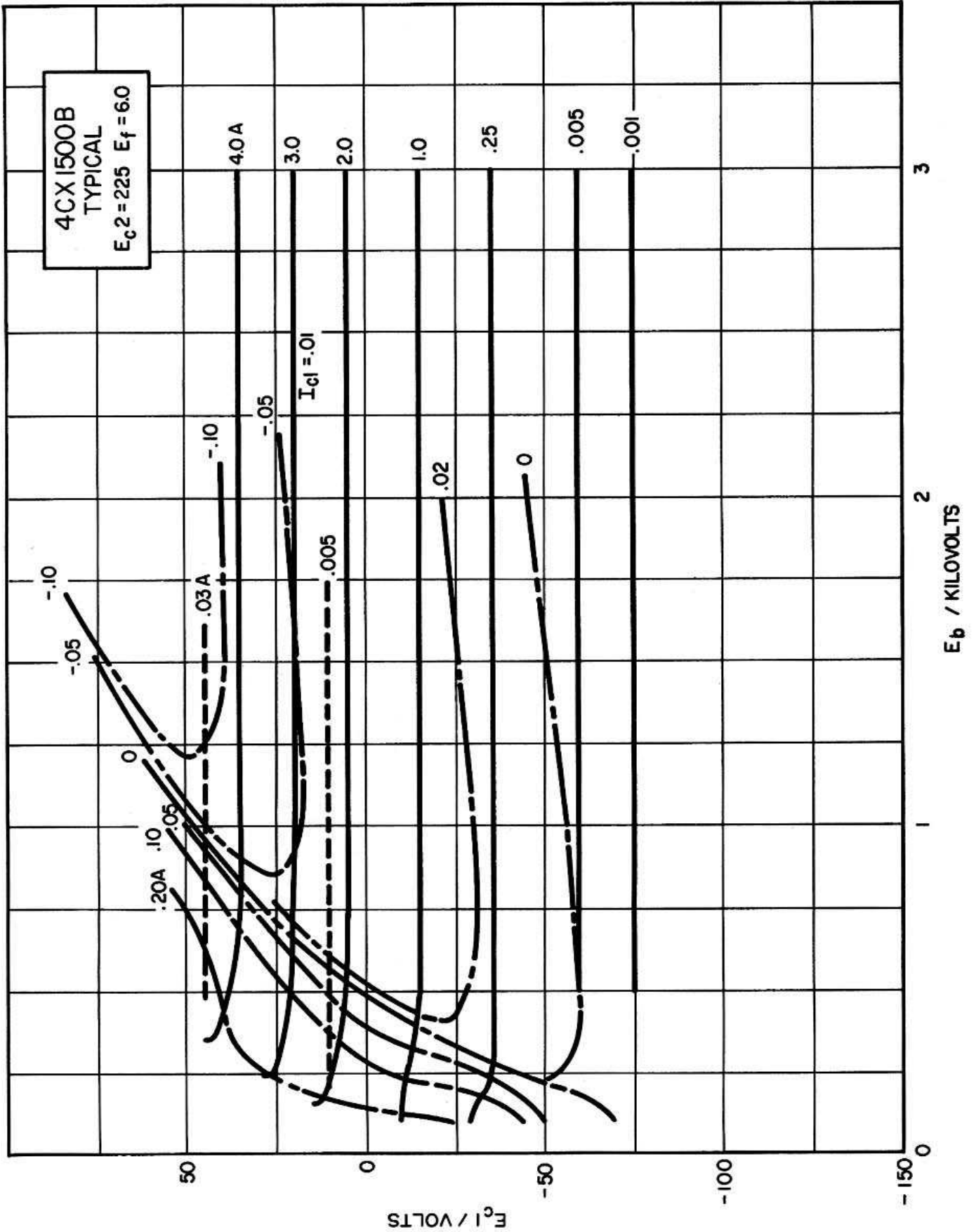



4CX1500B

