

Note: Typical operation data are based on conditions of adjusting the r-f grid drive to a specified plate current, maintaining fixed conditions of grid bias and screen voltage. It will be found that if this procedure is followed, there will be little variation in power output between tubes even though there may be some variation in grid and screen currents. Where grid bias is obtained principally by means of a grid resistor, to control plate current it is necessary to make the resistor adjustable.

▶ AUDIO-FREQUENCY POWER AMPLIFIER AND MODULATOR

MAXIMUM RATINGS (PER TUBE)

D-C PLATE VOLTAGE	- - - - -	3000 MAX. VOLTS
D-C SCREEN VOLTAGE	- - - - -	600 MAX. VOLTS
MAX-SIGNAL D-C PLATE CURRENT, PER TUBE	- - - - -	150 MAX. MA
PLATE DISSIPATION, PER TUBE	- - - - -	65 MAX. WATTS
SCREEN DISSIPATION, PER TUBE	- - - - -	10 MAX. WATTS

TYPICAL OPERATION

Class-AB₁ (Sinusoidal wave, two tubes unless otherwise specified)

D-C Plate Voltage	- - - - -	1000	1500	1750	volts
D-C Screen Voltage	- - - - -	500	500	500	volts
D-C Grid Voltage ¹	- - - - -	-100	-110	-115	volts
Zero-Signal D-C Plate Current	- - - - -	60	60	40	ma
Max-Signal D-C Plate Current	- - - - -	170	180	170	ma
Max-Signal D-C Screen Current*	- - - - -	30	20	23	ma
Max-Signal D-C Grid Current	- - - - -	0	0	0	
Effective Plate-to-Plate Load	- - - - -	9000	15,000	20,000	ohms
Peak A-F Grid Voltage (per tube)	- - - - -	85	85	90	volts
Max-Signal Plate Power Input	- - - - -	170	270	300	watts
Max-Signal Plate Power Output	- - - - -	80	145	175	watts

*Approximate value.

¹Adjust to stated zero-signal D-C Plate Current.

The effective grid circuit resistance for each tube must not exceed 250,000 ohms.

TYPICAL OPERATION

Class-AB₂ (Sinusoidal wave, two tubes unless otherwise specified)

D-C Plate Voltage	- - - - -	600	1000	1500	1800	volts
D-C Screen Voltage	- - - - -	250	250	250	250	volts
D-C Grid Voltage**	- - - - -	-40	-40	-45	-50	volts
Zero-Signal D-C Plate Current	- - - - -	60	60	60	50	ma
Max-Signal D-C Plate Current	- - - - -	300	300	250	220	ma
Max-Signal D-C Screen Current*	- - - - -	80	60	40	30	ma
Effective Plate-to-Plate Load	- - - - -	3600	6800	14,000	20,000	ohms
Peak A-F Grid Voltage (per tube)	- - - - -	120	105	100	90	volts
Max-Signal Peak Driving Power*	- - - - -	7.4	6.0	3.8	2.6	watts
Max-Signal Nominal Driving Power*	- - - - -	3.7	3.0	1.9	1.3	watts
Max-Signal Plate Power Input	- - - - -	160	300	375	395	watts
Max-Signal Plate Power Output	- - - - -	90	170	250	270	watts

*Approximate values.

**Adjust to stated Zero-Signal D-C Plate Current.

▶ RADIO-FREQUENCY LINEAR POWER AMPLIFIER SINGLE SIDE BAND SUPPRESSED CARRIER

Class-B (One tube)

MAXIMUM RATINGS

D-C PLATE VOLTAGE	- - - - -	3000 MAX. VOLTS
D-C SCREEN VOLTAGE	- - - - -	600 MAX. VOLTS
PLATE DISSIPATION	- - - - -	65 MAX. WATTS
SCREEN DISSIPATION	- - - - -	10 MAX. WATTS
GRID DISSIPATION	- - - - -	5 MAX. WATTS

*Adjust to stated Zero-Signal Plate Current.

**Approximate values.

***Due to the intermittent nature of voice, average dissipation is considerably less than Max-Signal Dissipation. If the amplifier is to be tested using a sine-wave signal source, arrangements must be made to lower the duty.

TYPICAL OPERATION

Class-AB₂ (Voice wave only, per tube)

D-C Plate Voltage	- - - - -	1500	2000	2500	volts
D-C Screen Voltage	- - - - -	300	400	500	volts
D-C Grid Voltage*	- - - - -	-55	-80	-105	volts
Zero-Signal D-C Plate Current	- - - - -	35	25	20	ma
Max-Signal D-C Plate Current	- - - - -	200	270	230	ma
Max-Signal D-C Screen Current**	- - - - -	45	65	45	ma
Max-Signal Peak R-F Grid Voltage	- - - - -	150	190	165	volts
Max-Signal D-C Grid Current**	- - - - -	15	20	8	ma
Max-Signal Driving Power**	- - - - -	2.3	3.8	1.3	watts
Max-Signal Plate Power Input	- - - - -	300	540	575	watts
Max-Signal Plate Dissipation***	- - - - -	105	190	225	watts
Average Plate Dissipation	- - - - -	60	65	65	watts
Max-Signal Useful Power Output	- - - - -	150	300	325	watts

IF IT IS DESIRED TO OPERATE THIS TUBE UNDER CONDITIONS WIDELY DIFFERENT FROM THOSE GIVEN UNDER "TYPICAL OPERATIONS," POSSIBLY EXCEEDING MAXIMUM RATINGS, WRITE EITEL-McCULLOUGH, INC., FOR INFORMATION AND RECOMMENDATIONS.

APPLICATION

MECHANICAL

Mounting—The 4-65A must be mounted vertically, base up or base down. The socket must provide clearance for the glass tip-off which extends from the center of the base. A flexible connecting strap should be provided between the plate terminal and the external plate circuit, and the Eimac HR-6 cooler (or equivalent) used on the tube plate lead. The socket must not apply lateral pressure against the base pins. The tube must be protected from severe vibration and shock.

Adequate ventilation must be provided so that the seals and envelope under operating conditions do not exceed 225°C. For operation above 50 Mc., the plate voltage should be reduced, or special attention should be given to seal cooling.

In intermittent-service applications where the "on" time does not exceed a total of five minutes in any ten minute period, plate seal temperatures as high as 250°C are permissible. When the ambient temperature does not exceed 30°C it will not ordinarily be necessary to provide forced cooling of the bulb and plate seal to hold the temperature below this maximum at frequencies below 50 Mc, provided that a heat-radiating plate connector is used, and the tube is so located that normal circulation of air past the envelope is not impeded.

ELECTRICAL

Filament Voltage—The filament voltage, as measured directly at the filament pins, should be between 5.7 volts and 6.3 volts.

Bias Voltage—D-C bias voltage for the 4-65A should not exceed -500 volts. If grid-leak bias is used, suitable protective means must be provided to prevent excessive plate or screen dissipation in the event of loss of excitation.

Grid Dissipation—Grid dissipation for the 4-65A should not be allowed to exceed five watts. Grid dissipation may be calculated from the following expression:

$$P_g = e_{cmp} I_c$$

where P_g = Grid dissipation,
 e_{cmp} = Peak positive grid voltage, and
 I_c = D-c grid current.

e_{cmp} may be measured by means of a suitable peak voltmeter connected between filament and grid.*

Screen Voltage—The D-C screen voltage for the 4-65A should not exceed 400 volts except in the case of class-AB audio operation and Single Side Band R-F amplifier operation where it should not exceed 600 volts.

Screen Dissipation—The power dissipated by the screen of the 4-65A must not exceed 10 watts. Screen dissipation is likely to rise to excessive values when the plate volt-

age, bias voltage or plate load is removed with filament and screen voltages applied. Suitable protective means must be provided to limit screen dissipation to 10 watts in the event of circuit failure.

Plate Voltage—The plate-supply voltage for the 4-65A should not exceed 3,000 volts. Above 50 Mc. it is advisable to use a lower plate voltage than the maximum, since the seal heating due to R-F charging currents in the screen leads increases with plate voltage and frequency. See instructions on seal cooling under "Mechanical" and "Shielding."

Plate Dissipation—Under normal operating conditions, the plate dissipation of the 4-65A should not be allowed to exceed 65 watts in unmodulated applications.

In high-level-modulated amplifier applications, the maximum allowable carrier-condition plate dissipation is 45 watts.

Plate dissipation in excess of maximum rating is permissible for short periods of time, such as during tuning procedures.

OPERATION

Class-C FM or Telegraphy—The 4-65A may be operated as a class-C FM or telegraph amplifier without neutralization up to 110 Mc. if reasonable precautions are taken to prevent coupling between input and output circuits external to the tube. In single ended circuits, plate, grid, filament and screen by-pass capacitors should be returned through the shortest possible leads to a common chassis point. In push-pull applications the filament and screen terminals of each tube should be by-passed to a common chassis point by the shortest possible leads, and short, heavy leads should be used to interconnect the screens and filaments of the two tubes. Care should be taken to prevent leakage of radio-frequency energy to leads entering the amplifier, in order to minimize grid-plate coupling between these leads external to the amplifier.

Where shielding is adequate, the feedback at frequencies above 110 Mc. is due principally to screen-lead-inductance effects, and it becomes necessary to introduce in-phase voltage from the plate circuit into the grid circuit. This can be done by adding capacitance between plate and grid external to the tube. Ordinarily, a small metal tab approximately 3/4" square and located adjacent to the envelope opposite the plate will suffice for neutralization. Means should be provided for adjusting the

*For suitable peak V.T.V.M. circuits see, for instance, "Vacuum Tube Ratings," Eimac News, January 1945. This article is available in reprint form on request.

spacing between the neutralizing capacitor plate and the envelope. An alternate neutralization scheme for use above 110 Mc is illustrated in the diagram on page 4. In this circuit, feedback is eliminated by series-tuning the screen to ground with a small capacitor. The socket screen terminals should be strapped together as shown on the diagram, by the shortest possible lead, and the lead from the mid point of this screen strap to the capacitor, C, and from the capacitor to ground should be made as short as possible.

Driving power and power output under maximum output and plate voltage conditions are shown below. The power output shown is the actual plate power delivered by the tube; the power delivered to the load will depend upon the efficiency of the plate tank and output coupling system. The driving power is likewise the driving power required by the tube (includes bias loss). The driver output power should exceed the driving power requirements by a sufficient margin to allow for coupling-circuit losses. The use of silver-plated linear tank-circuit elements is recommended for all frequencies above 75 Mc.

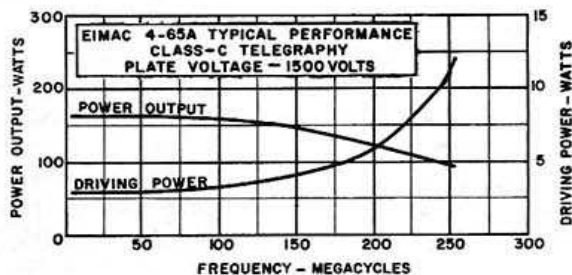

Class-C AM Telephony—The R-F circuit considerations discussed above under Class-C FM or Telegraphy also apply to amplitude-modulated operation of the 4-65A. When the 4-65A is used as a class-C high-level-modulated

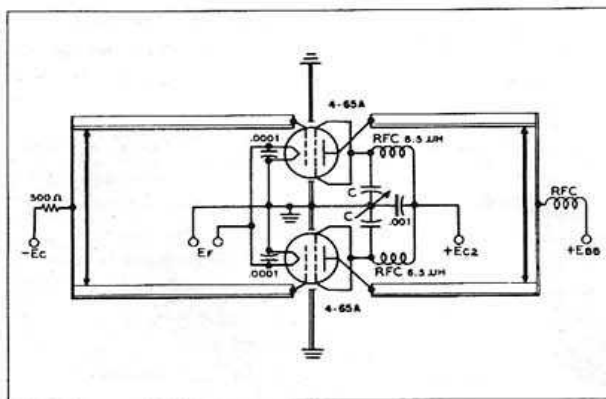

Screen-tuning neutralization circuit for use above 100 Mc. C is a small split-stator capacitor.

$$C_{(\mu\mu f)} = \frac{640,000}{f^2 (\text{Mc.})}, \text{ approx.}$$

amplifier, both the plate and screen should be modulated. Modulation voltage for the screen is easily obtained by supplying the screen voltage via a series dropping resistor from the unmodulated plate supply, or by the use of an audio-frequency reactor in the positive screen-supply lead, or from a separate winding on the modulation transformer. When screen modulation is obtained by either the series-resistor or the audio-reactor methods, the audio-frequency variations in screen current which result from the variations in plate voltage as the plate is modulated automatically give the required screen modulation. Where a reactor is used, it should have a rated inductance of not less than 10 henries divided by the number of tubes in the modulated amplifier and a maximum current rating of two to three times the operating D-C screen current. To prevent phase-shift between the screen and plate modulation voltages at high audio frequencies, the screen by-pass capacitor should be no larger than necessary for adequate R-F by-passing.

For high-level modulated service, the use of partial grid-leak bias is recommended. Any by-pass capacitors placed across the grid-leak resistance should have a reactance at the highest modulation frequency equal to at least twice the grid-leak resistance.

Class-AB₁ and Class-AB₂ Audio—Two 4-65As may be used in a push-pull circuit to give relatively high audio output power at low distortion. Maximum ratings and typical operating conditions for class-AB₁ and class-AB₂ audio operation are given in the tabulated data.

Screen voltage should be obtained from a source having reasonably good regulation, to prevent variations in screen voltage from zero-signal to maximum-signal conditions. The use of voltage regulator tubes in a standard circuit should provide adequate regulation.

Grid bias voltage for class-AB₂ service may be obtained from batteries or from a small fixed-bias supply. When a bias supply is used, the D-C resistance of the bias source should not exceed 250 ohms. Under class-AB₁ conditions the effective grid-circuit resistance should not exceed 250,000 ohms.

The peak driving power figures given in the class-AB₂ tabulated data are included to make possible an accurate determination of the required driver output power. The driver amplifier must be capable of supplying the peak driving power without distortion. The driver stage should, therefore, be capable of providing an undistorted average output equal to half the peak driving power requirement. A small amount of additional driver output should be provided to allow for losses in the coupling transformer.

In some cases the maximum-signal plate dissipation shown under "Typical Operation" is less than the maximum rated plate dissipation of 4-65A. In these cases, with sine wave modulation, the plate dissipation reaches a maximum value, equal to the maximum rating, at a

point somewhat below maximum-signal conditions.

The power output figures given in the tabulated data refer to the total power output from the amplifier tubes. The useful power output will be from 5 to 15 per cent less than the figures shown, due to losses in the output transformer.

Because of the intermittent nature of the voice, and the low average power, it is possible in cases where size and weight are important to operate a class-AB stage at higher peak power values than those indicated for sine wave.

In order to obtain peak power above that shown for sine wave (peak is twice average for sine wave), the plate-to-plate load impedance must be made proportionately lower than the value shown for a particular plate voltage. Also, more peak driving power will be required. At no time should the average plate or grid dissipation exceed the maximum values shown.

KEYING THE TETRODE AMPLIFIER

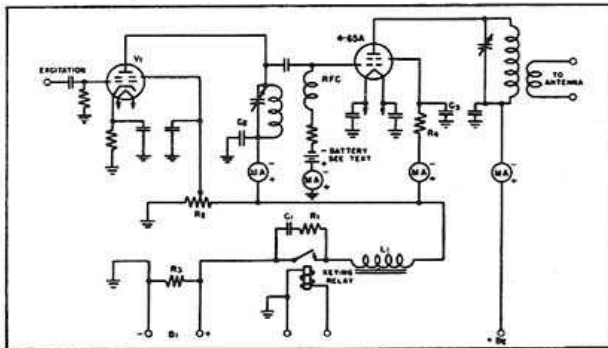

Tetrode Keying Circuit

The flow of plate current in an R-F tetrode amplifier depends not only on the control grid bias and excitation, but also on the voltage applied to the screen grid.

One easy method of keying is to remove the excitation and screen grid voltage simultaneously, while leaving the plate voltage still applied to the amplifier stage. This method also has an advantage in that the final tube can be made to draw a safe amount of current key-up position, maintaining a steadier drain on the power supply while keying. This tends to minimize "blinking lights" on weak AC supply lines when using moderate power. By properly choosing the values of L, C, and R, in the circuit, perfectly clean-cut highest speed hand keying can easily be obtained that is entirely devoid of clicks.

The keying circuit is shown in the diagram and V₁ is the driver tube, which may be any one of the small tetrodes such as an 807, 2E26, 6146, 6L6 or 6AG7, used either as a frequency multiplier or a straight-through amplifier. This tube should furnish about five watts of

output power which allows ample driving power for one 4-65A, including circuit losses. Capacitance coupling is shown in the diagram, but this, of course, could just as well be link coupling.

Steady driving power is fed to the grid of V₁ from the exciter. The keying circuit controls the plate and screen voltages on V₁, as well as the screen voltage on the 4-65A, all obtained from a common power supply B₁. This supply should furnish sufficient voltage to the plate of V₁ to obtain the necessary driving power. Normally this voltage will be about the correct voltage for the screen of the 4-65A and resistor R₄ may be omitted.

When the key is up there is no excitation to the 4-65A, and consequently no grid leak bias. At the same time, the screen voltage has also been removed so that very little current is drawn by the plate. With plate voltages up to 2000 volts, the amount of current drawn is not sufficient to heat the plate beyond its rated plate dissipation and a fixed bias is not required. However, with plate voltages over 2000 volts, a small fixed bias supply is needed to keep the plate dissipation within the rated limit. An ordinary 22½ volt C battery in the control grid circuit will furnish sufficient bias to completely cut the plate current off at 3000 volts, while some lower value of bias can be used to permit a safe amount of current to flow in key-up position, presenting a more constant load to the power supply.

A tapped resistor R₂ serves to supply screen voltage to V₁ and by adjusting this tap, the excitation to the 4-65A may be easily controlled. This method of controlling the output of a tetrode is not recommended in the larger tetrodes, however, as it is wasteful of power and the lowered power output obtained is due to a loss in efficiency. R₂ also serves as a means of keeping the screen of the 4-65A at ground potential under key-up conditions, stabilizing the circuit. R₃ is the normal power supply bleeder.

The keying relay must be insulated to withstand the driver plate voltage. Key clicks may be completely eliminated by the proper selection of L₁, R₁ and C₁ in series with and across the relay. In many applications values of 500 ohms for R₁ and 0.25 μfd for C₁ have been found entirely satisfactory. Choke L₁ is best selected by trial and usually is on the order of 5 henries. A satisfactory choke for this purpose can be made by using any small power-supply choke, capable of handling the combined current of the final screen grid and the driver stage, and adjusting the air gap to give the proper inductance. This may be checked by listening for clean keying on the "make" side of the signal or by observation in a 'scope.

R-F by-pass condensers C₂ and C₃ will have some effect on the required value of L₁ as well as C₁. These by-pass condensers should be kept at as small a value of capacity as is needed. In most cases .002 μfd is sufficient.

SHIELDING

The internal feedback of the tetrode has been substantially eliminated, and in order to fully utilize this advantage, it is essential that the design of the equipment completely eliminates any feedback external to the tube. This means complete shielding of the output circuit from the input circuit and earlier stages, proper reduction to low values of the inductance of the screen lead to the R-F ground, and elimination of R-F feedback in any common power supply leads.

Complete shielding is easily achieved by mounting the socket of the tube flush with the deck of the chassis as shown in the sketch on page 7.

The holes in the socket permit the flow of convection air currents from below the chassis up past the seals in the base of the tube. This flow of air is essential to cool the tube and in cases where the complete under part of the chassis is enclosed for electrical shielding, screened holes or louvers should be provided to permit air circulation. Note that shielding is completed by aligning the internal screen shield with the chassis deck and by proper R-F by-passing of the screen leads to R-F ground. The plate and output circuits should be kept above deck and the input circuit and circuits of earlier stages should be kept below deck or completely shielded.

DIFFERENT SCREEN VOLTAGES

The published characteristic curves of tetrodes are shown for the commonly used screen voltages. Occasionally it is desirable to operate the tetrode at some screen voltage other than that shown on the characteristic curves. It is a relatively simple matter to convert the published curves to corresponding curves at a different screen voltage by the method to be described.

This conversion method is based on the fact that if all inter-electrode voltages are either raised or lowered by the same relative amount, the shape of the voltage field pattern is not altered, nor will the current distribution be altered; the current lines will simply take on new proportionate values in accordance with the three-halves power law. This method fails only where insufficient cathode emission or high secondary emission affect the current values.

For instance, if the characteristic curves are shown at a screen voltage of 250 volts and it is desired to determine conditions at 500 screen volts, all voltage scales should be multiplied by the same factor that is applied to the screen voltage (in this case—2). The 1000 volt plate voltage point now becomes 2000 volts, the 50 volt grid voltage point, 100 volts, etc.

The current lines then all assume new values in accordance with the $3/2$ power law. Since the voltage was increased by a factor of 2, the current lines will all be increased in value by a factor of $2^{3/2}$ or 2.8. Then all the current values should be multiplied by the factor 2.8. The 100 ma. line becomes a 280 ma. line, etc.

Likewise, if the screen voltage given on the characteristic curve is higher than the conditions desired, the voltages should all be reduced by the same factor that is used to obtain the desired screen voltage. Correspond-

ingly, the current values will all be reduced by an amount equal to the $3/2$ power of this factor.

For convenience the $3/2$ power of commonly used factors is given below:

Voltage Factor	.25	.5	.75	1.0	1.25	1.50	1.75
Corresponding							
Current Factor	.125	.35	.65	1.0	1.4	1.84	2.3
Voltage Factor	2.0	2.25	2.5	2.75	3.0		
Corresponding							
Current Factor	2.8	3.4	4.0	4.6	5.2		

SINGLE SIDE BAND SUPPRESSED CARRIER OPERATION

The 4-65A may be operated as a class B linear amplifier in SSSC operation and peak power outputs of over 300 watts per tube may be readily obtained. This is made possible by the intermittent nature of the voice. If steady audio sine wave modulation is used, the single side band will be continuous and the stage will operate as a C-W class-B amplifier. With voice modulation the average power will run on the order of $1/5$ th of this continuous power.

The same precautions regarding shielding, coupling between input and output circuits, and proper R-F by-passing must be observed, as described under Class-C Telegraphy Operation.

Due to the widely varying nature of the load imposed on the power supplies by SSSC operation, it is essential that particular attention be given to obtaining good regulation in these supplies. The bias supply especially, should have excellent regulation, and the addition of a heavy bleeder to keep the supply well loaded will be found helpful.

Under conditions of zero speech signal, the operating bias is adjusted so as to give a plate dissipation of 50 watts at the desired plate and screen voltages. Due to the intermittent nature of voice, the average plate dissipation will rise only slightly under full speech modulation to approximately 65 watts. At the same time, however, the peak speech power output of over 300 watts is obtained.

SSSC TUNING PROCEDURE

Tuning the SSSC transmitter is best accomplished with the aid of an audio frequency oscillator and a cathode-ray oscilloscope. The audio oscillator should be capable of delivering a sine wave output of a frequency of around 800 to 1000 cycles so that the frequency will be somewhere near the middle of the pass-band of the audio system. Since successful operation of the class-B stage depends on good linearity and the capability of delivering full power at highest audio levels, the final tuning should be made under conditions simulating peak modulation conditions. If a continuous sine wave from the audio oscillator is used for tuning purposes, the average power at full modulation would be about five times that of speech under similar conditions of single side band operation and the final amplifier would be subjected to a heavy overload. One method of lowering the duty cycle of the audio oscillator to closer approxi-

mate speech conditions would be to modulate the oscillator with a low frequency.

An alternate method would be to use the continuous audio sine wave, making all adjustments at half voltages and half currents on the screen and plate, thus reducing the power to one quarter. The stand-by plate dissipation under these conditions should be set at about 10 watts. Following these adjustments, minor adjustments at full voltages and 50 watts of stand-by plate dissipation could then be made, but only allowing the full power to remain on for ten or fifteen second intervals.

The first step is to loosely couple the oscilloscope to the output of the exciter unit. The final amplifier with its filament and bias voltages turned on should also be coupled to the exciter at this time. With the audio oscillator running, adjust the exciter unit so that it delivers double side band signals. Using a linear sweep on the oscilloscope, the double side band pattern will appear on the screen the same as that obtained from a 100% sine wave modulated AM signal. Next vary the audio gain control so that the exciter can be checked for linearity. When the peaks of the envelope start to flatten out the upper limit of the exciter output has been reached and the maximum gain setting should be noted. The coupling to the final stage should be varied during this process and a point of optimum coupling determined by watching the oscilloscope pattern and the grid meter in the final stage.

Next, adjust the exciter for single side band operation and if it is working properly, the pattern on the oscilloscope will resemble an unmodulated AM carrier. The phasing controls should be adjusted so as to make the envelope as smooth on the top and bottom as possible. If the above conditions are satisfied, the exciter unit can be assumed to be operating satisfactorily.

Next, loosely couple the oscilloscope link to the output of the final amplifier and again adjust the exciter unit to give double side band output.

If the reduced duty cycle method is used, the following tuning procedure may be followed:

1. Cut the audio output to zero.
2. Apply 120 volts of bias to the 4-65A control grid.
3. Apply the operating plate voltage followed by the operating screen voltage.
4. Reduce bias voltage to obtain 50 watts of stand-by plate dissipation.
5. Increase audio gain, checking the oscilloscope pattern for linearity as in the case of the exciter, and adjust for optimum antenna coupling.
6. Re-adjust exciter unit for single side band operation.
7. Disconnect test signal and connect microphone.
8. Adjust the audio gain so that the voice peaks give the same deflection on the oscilloscope screen as was obtained from the test signal peaks.

If the alternate method is used with a 100% duty cycle from the audio oscillator, then step 3 should be to apply half voltages and the stand-by plate dissipation should be set at 10 watts.

After the audio oscillator is disconnected and step 8 completed at half voltages, the full voltages can then be applied and the stand-by plate dissipation adjusted for 50 watts.

It is essential that the microphone cable be well shielded and grounded to avoid R-F feedback that might not occur when the lower impedance audio oscillator is used as an audio source.

Typical operational data are given for SSSC in the first part of this data sheet.

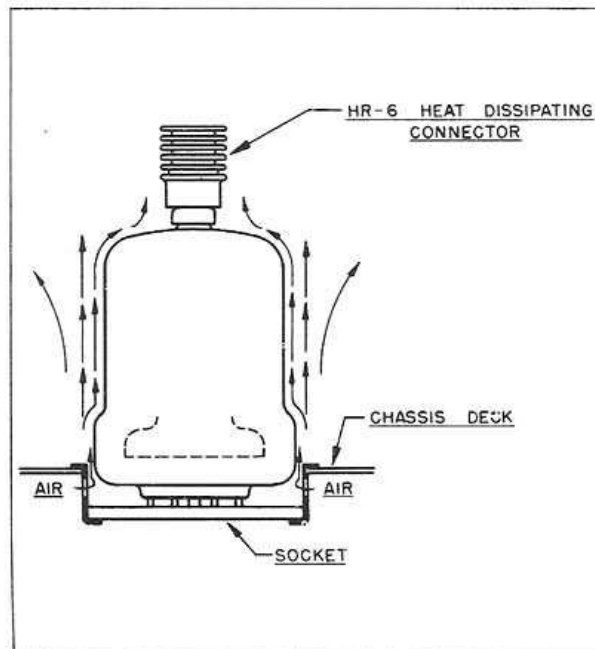

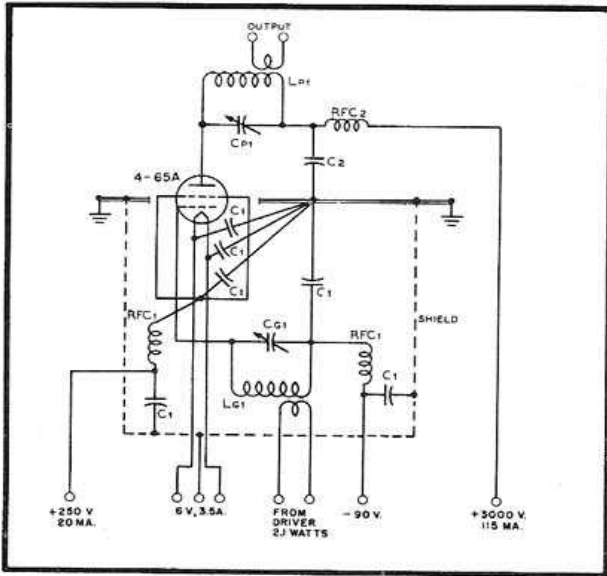

Typical radio-frequency power amplifier circuit, Class-C telegraphy, 345 watts input.

COMPONENTS FOR TYPICAL CIRCUITS

- L_{p1}-C_{p1}—Tank circuit appropriate for operating frequency; Q=12. Capacitor plate spacing=.200".
- L_{p2}-C_{p2}—Tank circuit appropriate for operating frequency; Q=12. Capacitor plate spacing=.200".
- L_{p3}-C_{p3}—Tank circuit appropriate for operating frequency; Q=12. Capacitor plate spacing=.375".
- L_{g1}-C_{g1}—Tuned circuit appropriate for operating frequency.
- L_{g2}-C_{g2}—Tuned circuit appropriate for operating frequency.
- C₁—.002- μ fd. 500V Mica
- C₂—.002- μ fd. 5000V Mica
- C₃—.001- μ fd. 2500V Mica
- C₄—.1- μ fd. 1000V paper
- C₅—.1- μ fd. 600 V paper
- C₆—16- μ fd. 450V Electrolytic
- C₇—10- μ fd. 100V Electrolytic
- R₁—53,000 ohms 200 watt—60,000 ohm adjustable
- R₂—250,000 ohms 1 watt
- R₃—5,000 ohms 5 watt
- R₄—25,000 ohms 2 watts
- R₅—26,500 ohms 200 watts—30,000 ohm adjustable
- R₆—2,500 ohms 5 watts
- R₇—750 ohms 5 watts
- RFC₁—2.5 mhy. 125 ma. R-F choke
- RFC₂—1 mhy. 500 ma. R-F choke
- T₁—150 watt modulation transformer; ratio primary to secondary impedance approx. 1:1.1 Pri. impedance 15,000 ohms, sec. impedance 16,700 ohms.
- T₂—5 watt driver transformer impedance ratio primary to 1/2 secondary 1.5:1.
- T₃—300 watt modulation transformer; impedance ratio pri. to sec. approx. 2.4:1; Pri. impedance=20,000 ohms, sec. impedance=8,333 ohms.

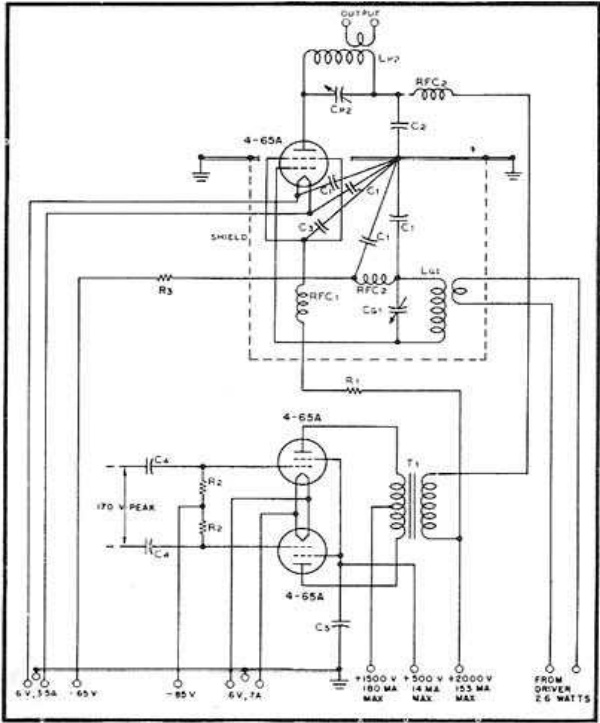

Typical high-level-modulated R-F amplifier, 240 watts plate input. Modulator requires zero driving power.

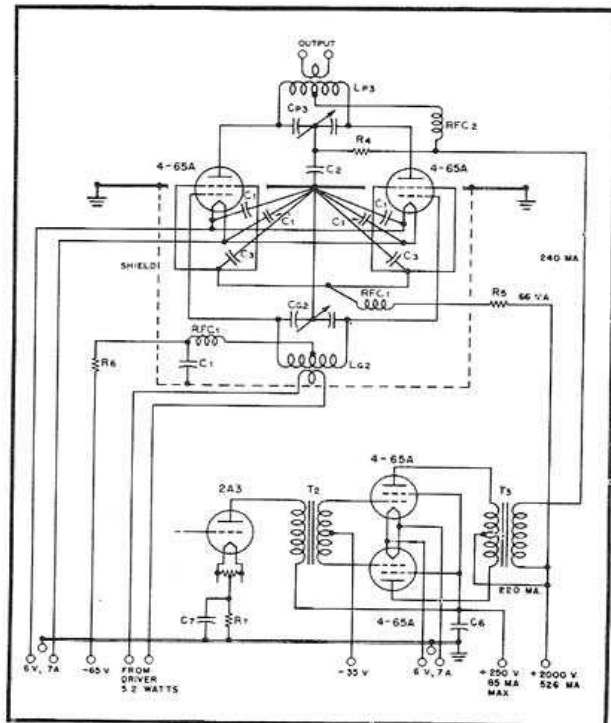

Typical high-level-modulated R-F amplifier circuit, with modulator and driver stages, 480 watts plate input.

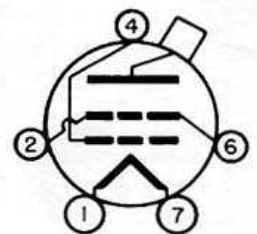
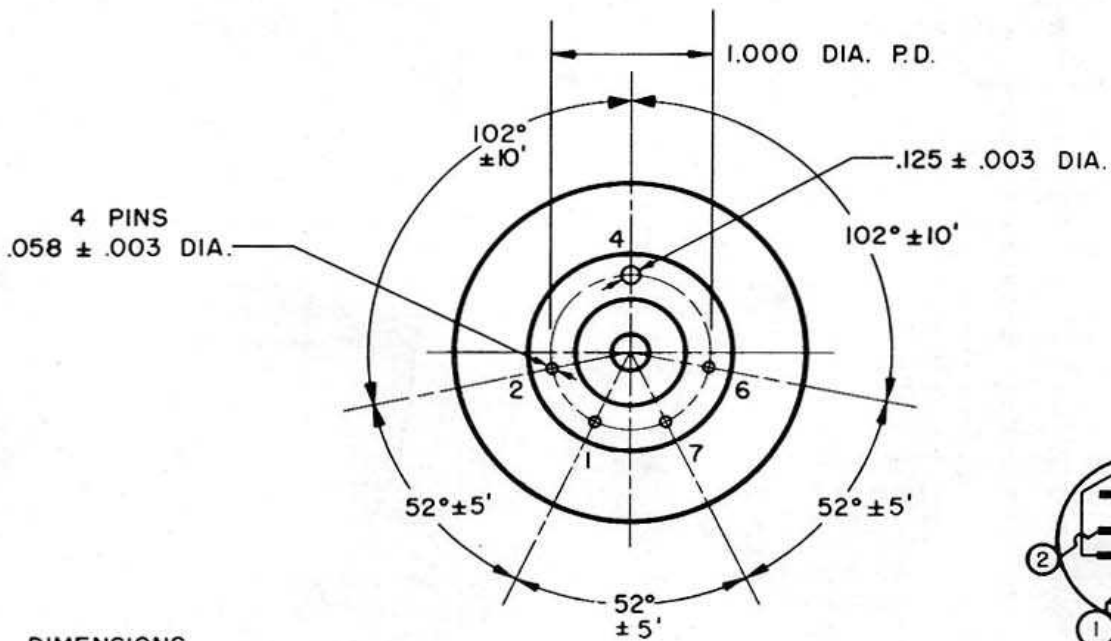
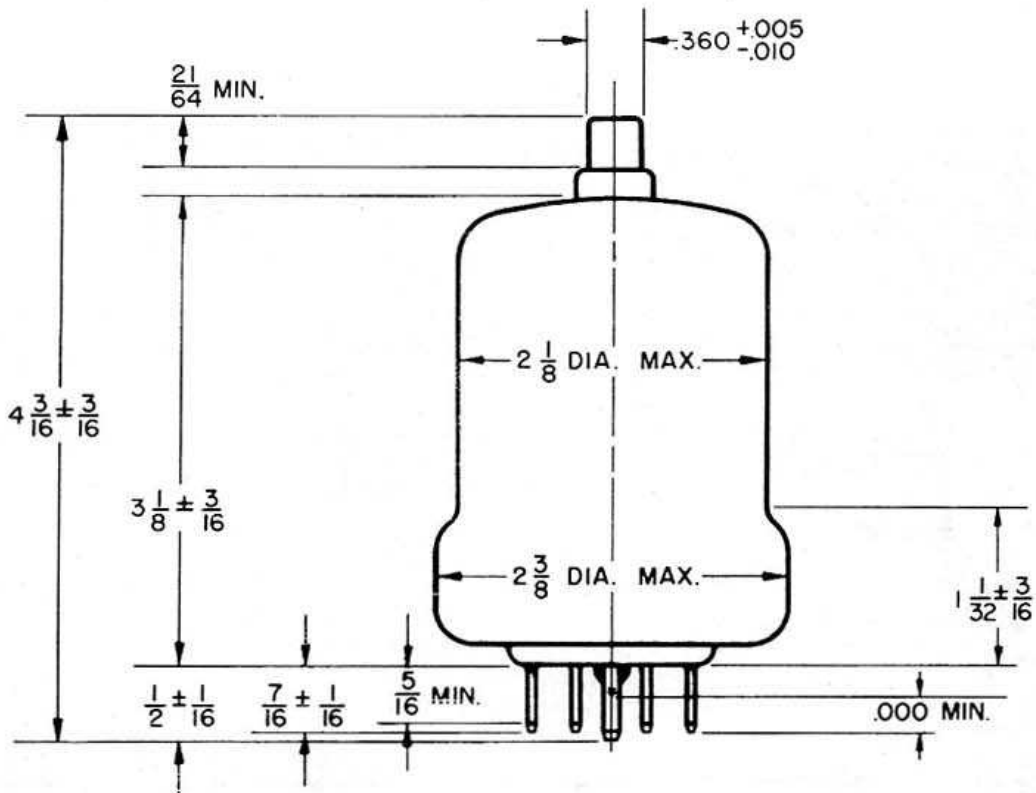

ALL DIMENSIONS
IN INCHES

BOTTOM VIEW

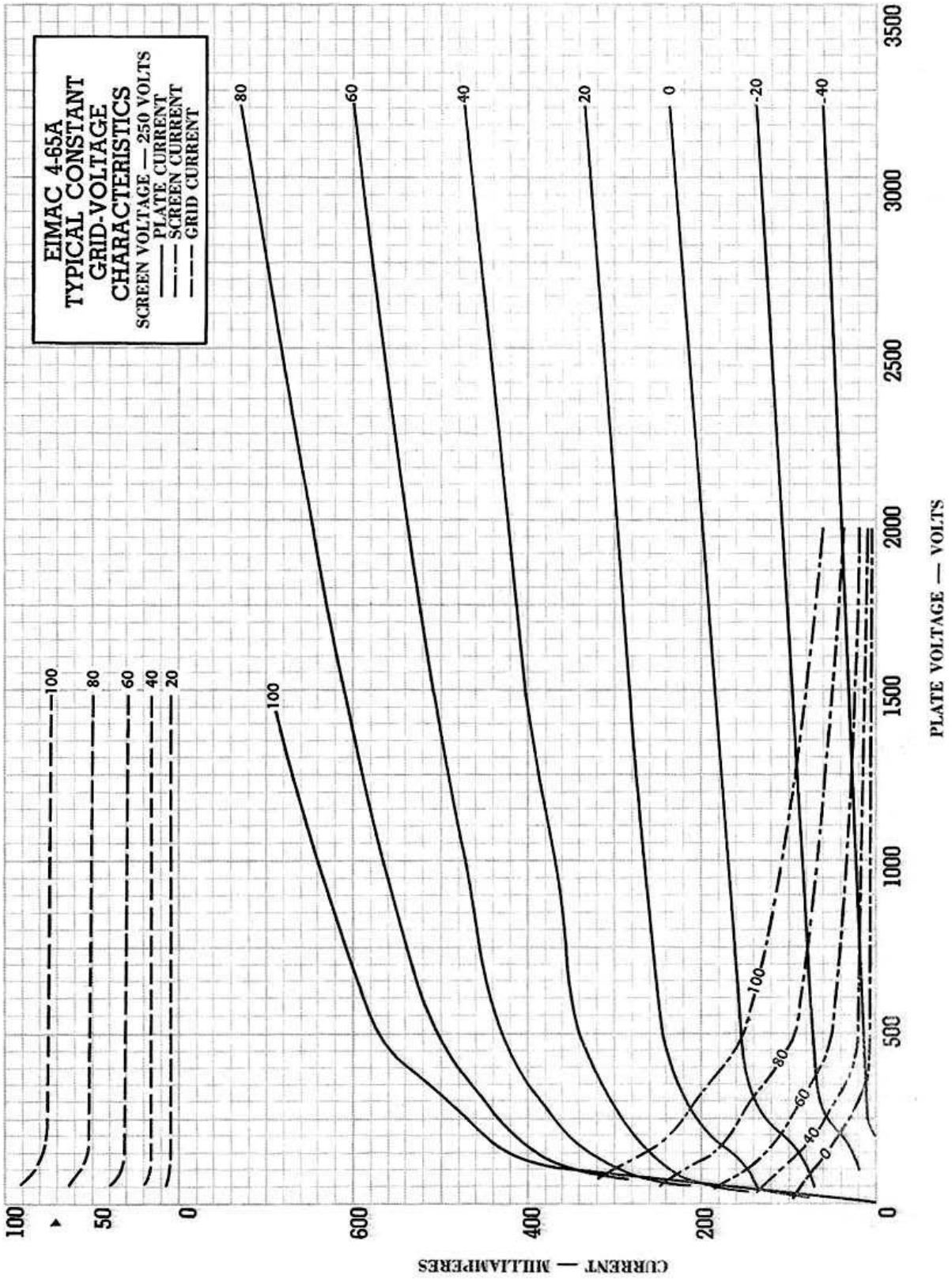

▶ Indicates change from sheet dated 1-30-53

