



TECHNICAL DATA

**YU-181  
HIGH-MU POWER TRIODE**



TENTATIVE

The EIMAC YU-181 is a high mu, forced air cooled, rugged, ceramic/metal power triode intended for use as a grounded grid, zero bias class AB<sub>2</sub> amplifier.

GENERAL CHARACTERISTICS<sup>1</sup>

ELECTRICAL

Filament: Thoriated Tungsten

Voltage .....	6.3 Volts
Current .....	25 Amperes
Maximum Frequency .....	110 MHz
Amplification Factor (Estimated) .....	200

Interelectrode Capacitance (Estimated)<sup>2</sup>

C <sub>in</sub> .....	17.6 pF
C <sub>out</sub> .....	0.08 pF
C <sub>gp</sub> .....	9.7 pF

<sup>1</sup>Characteristics and operating values are based upon performance tests. These figures may change without notice as a result of additional data or product refinement. Varian Power Grid & X-Ray Tube Products should be consulted before using this information for final equipment design.

<sup>2</sup>Capacitance values are for a cold tube as measured in a special shielded fixture.



# YU-181

## TYPICAL OPERATION

DC Plate Voltage .....	4000 Volts
DC Plate Current .....	562 mA
DC Grid Current .....	163 mA
Total Power Out .....	1615 Watts
Plate Dissipation .....	670 Watts
Grid Impedance .....	76 Ohms
Drive Power .....	53 Watts

## ABSOLUTE MAXIMUM RATINGS

DC Plate Voltage .....	5.5 kV
DC Plate Current .....	800 mA
Plate Dissipation .....	1200 Watts
Grid Dissipation .....	50 Watts

## MECHANICAL

Cooling ..... Forced Air

### Maximum Operating Temperature:

Plate Seal .....	250°C
Base Seal .....	250°C

Operating Position ..... Vertical, base up or down

## APPLICATION

### MECHANICAL

**MOUNTING** - The YU-181 must be operated vertically, base up or down. A flexible connecting strap should be provided between the plate connector and the external plate circuit. The tube must be protected from severe vibration and shock.

**SOCKET** - The EIMAC SK-410 air system socket will fit the pin circle of the YU-181. As the YU-181 is made to have the grid directly grounded, the air flow data is the anode fin drop only.

**COOLING** - Forced air cooling is required to maintain the base seals at a temperature below 250°C, and the plate seal at a temperature below 250°C. Air flow requirements to maintain the above maximum temperatures are shown on cooling data curve.

### ELECTRICAL

**ABSOLUTE MAXIMUM RATINGS** - Values shown for each type of service are based on the "absolute system" and are not to be exceeded under any service conditions. These ratings are limiting values outside which the serviceability of the tube may be impaired. In order not to exceed absolute ratings, the equipment designer has the responsibility of determining an average design value for each rating below the absolute value of that rating by a safety factor so that the absolute values will never be exceeded under any usual conditions of supply voltage variation in the equipment itself. It does not necessarily follow that combinations of absolute maximum ratings can be attained simultaneously.

**ZERO-BIAS OPERATION** - Operation at zero bias is not recommended with plate voltages over 4000 since plate dissipation may be exceeded. A zener diode placing positive bias on the cathode or other constant

voltage source may be used to reduce zero signal plate current at plate potentials over 4000 Volts.

**CLASS-C OPERATION** - Although specifically designed for linear amplifier service, the YU-181 may be operated as a class-C power amplifier or oscillator or as a plate modulated radio frequency power amplifier. The zero bias characteristic of the YU-181 can be used to advantage in class-C amplifiers operating at plate voltages of 4000 Volts or below by employing only grid resistor bias. If driving power fails, plate dissipation is then kept to a low value because the tube will be operating at the normal static zero bias conditions.

**FILAMENT OPERATION** - The rated filament voltage for the YU-181 is 6.3 Volts. Filament voltage, as measured at the socket, must be maintained within the range of 5.985 to 6.615 Volts to obtain maximum tube life.

For best tube life, the inrush current to the filament should be limited to two times normal current during turn on. This will minimize thermal stress of the thoriated tungsten filament wire, which can cause internal tube geometry changes with repeated cycling.

**INTERMODULATION DISTORTION** - Typical operating conditions with distortion values included are the result of data taken during actual operation at 2 megahertz. Intermodulation values listed are those measured at the full peak envelope power noted.

**INTERELECTRODE CAPACITANCE** - The actual internal interelectrode capacitance of a tube is influenced by many variables in most applications, such as stray capacitance to the chassis, capacitance added by the socket used, stray capacitance between the tube terminals, and wiring effects. To control the actual capacitance values within the tube, as the key component involved, the industry and military services



use a standard test procedure as described in Electronic Industries Association Standard RS-191. This requires the use of specially constructed test fixtures which effectively shield all external tube leads from each other and eliminate any capacitance reading to "ground." The test is performed on a cold tube. Other factors being equal, controlling internal tube capacitance in this way normally assures good interchangeability of tubes over a period of time, even when the tube may be made by different manufacturers. The capacitance values shown in the manufacturer's technical data, or test specifications, normally are taken in accordance with Standard RS-191.

The equipment designer is, therefore, cautioned to make allowance for the actual capacitance values which will exist in any normal application. Measurements should be taken with the socket and mounting which represent approximate final layout if capacitance values are highly significant in the design.

**INPUT CIRCUIT** - When the YU-181 is operated as a grounded grid rf amplifier, the use of a resonant tank in the cathode circuit is recommended in order to obtain greatest linearity and power output. For best results with a single ended amplifier, it is suggested that the cathode tank circuit operate at a Q of two or more.

**FAULT PROTECTION** - It is good practice to protect the tube from internal damage caused by an internal arc which may occur at high anode voltage.

**RF RADIATION** - Exposure to strong rf fields should be avoided, even

at relatively low frequencies. The dangers of rf radiation are more severe at UHF and microwave frequencies and can cause serious bodily and eye injuries. **CARDIAC PACEMAKERS MAY BE AFFECTED.**

**HOT SURFACES** - When the tube is used in air and air cooled, external surfaces of the tube may reach temperatures up to 200 degrees C and higher. In addition to the anode, the cathode insulator and cathode/heater surfaces may remain hot for an extended time after the tube is shut off. To prevent serious burns, take care to avoid any bodily contact with these surfaces both during, and for a reasonable cool down period after, tube operation.

**CAUTION - HIGH VOLTAGE** - *Operating voltage for the YU-181 can be deadly, so the equipment must be designed properly and operating precautions must be followed. Design equipment so that no one can come in contact with high voltages. All equipment must include safety enclosures for high voltage circuits and terminals, with interlock switches to open the primary circuits of the power supply and to discharge high voltage capacitors whenever access doors are opened. Interlock switches must not be bypassed or "cheated" to allow operation with access doors open. Always remember that HIGH VOLTAGE CAN KILL.*

**SPECIAL APPLICATIONS** - If it is desired to operate this tube under conditions different from those given here, write to the Power Grid Tube Marketing Department, Varian Power Grid & X-Ray Tube Products, 1678 South Pioneer Road, Salt Lake City, UT 84104, for information and recommendations.



YU-181

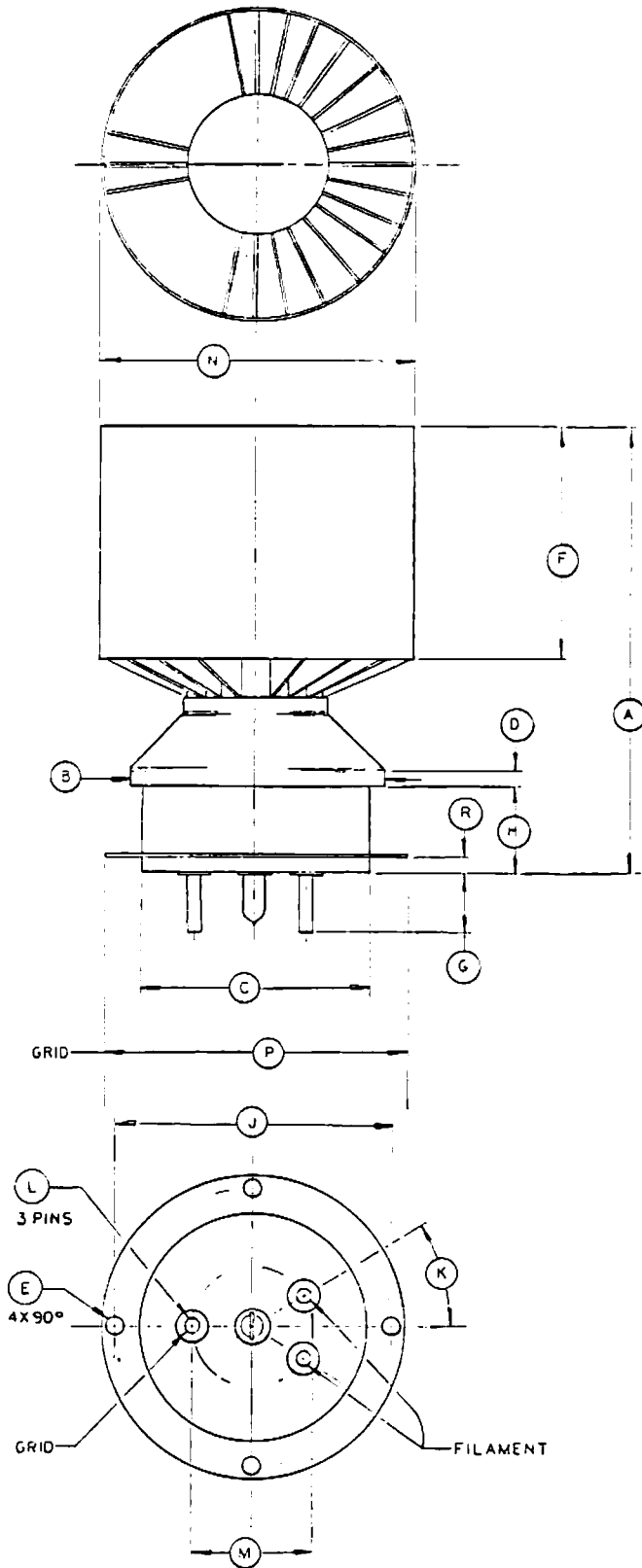

DIMENSIONAL DATA						
DIM.	INCHES			MILLIMETERS		
	MIN.	MAX.	REF.	MIN.	MAX.	REF.
A		4.770				
B			2.750			
C			2.500			
D			.212			
E	.124	.132				
F			2.250			
G	.700	.800				
H			.937			
J			3.062			
K			30°			
L	.185	.191				
M			1.250			
N			3.420			
P			3.250			
R	.165	.210				

NOTES:

1. Ref. dimensions are for info only & are not required for inspection purposes.
2. Base pins "L" are so aligned that they can be freely inserted into a gage 1/4" thk with hole dias. of .204 located on true centers by dims. "K" & "M"

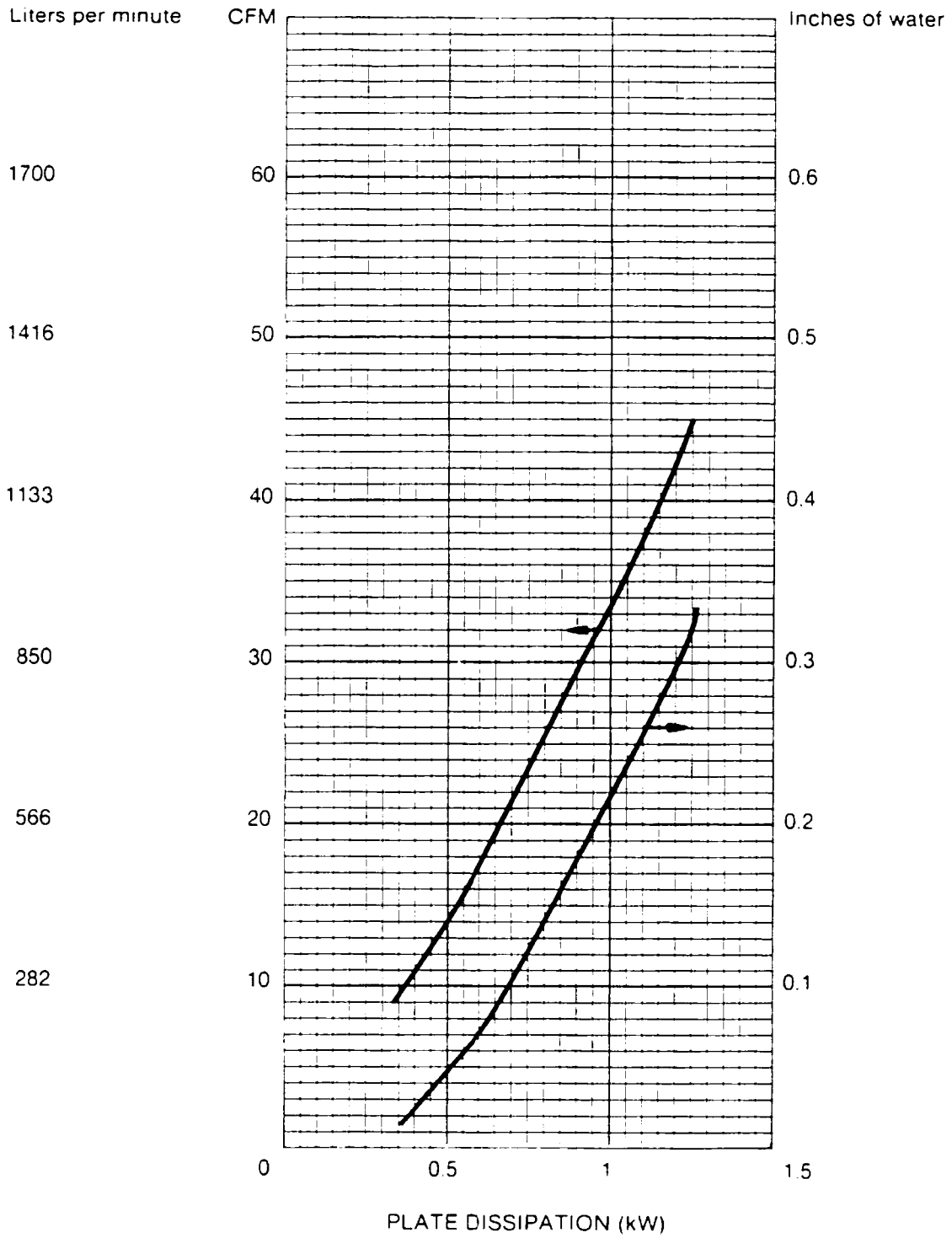

CFM and pressure required to keep anode temperature at 225°C.

Standard conditions 25°C at 29.92 In. Hg

1 PAS = .00407 X In. of water

1 cubic meter/min. = 2.832 X 10<sup>-2</sup> X CFM



YU-181

TYPICAL  
CONSTANT CURRENT  
CHARACTERISTICS

— PLATE CURRENT-AMPERES  
- - - GRID CURRENT-AMPERES

