



TECHNICAL DATA

3CW40,000 A5 MEDIUM-MU WATER-COOLED POWER TRIODE (FORMERLY Y-819)

The EIMAC 3CW40,000A5 is a water-cooled ceramic/metal power triode designed primarily for use as a radio-frequency amplifier. Its water-cooled anode is conservatively rated at 40 kilowatts of dissipation capability with low water flow and pressure drop.

Input of 100 kilowatts is permissible up to 90 megahertz. Plentiful reserve emission is available from its 1500 watt filament. The grid structure is rated at 1000 watts dissipation capability, making this tube an excellent choice for severe applications.

The tube's electrical characteristics closely match those of the Siemens RS2021 and it is therefore ideal as a retrofit.

GENERAL CHARACTERISTICS ¹

ELECTRICAL

Filament: Thoriated Tungsten

Voltage	12.0 ± 0.5 V
Current @ 12.0 Volts	120 A

Direct Interelectrode Capacitance (grounded cathode) ²

Cin	70.0 pF
Cout	2.3 pF
Cgp	43.0 pF

Amplification factor 55

Frequency of Maximum Rating (CW) 90 MHz

1. Characteristics and operating values are based on performance tests. These figures may change without notice as a result of additional data or product refinement. Varian EIMAC should be consulted before using this information for final equipment design.

2. Capacitance values are for a cold tube as measured in a specially-shielded fixture in accordance with Electronic Industries Association Standard RS-191.

MECHANICAL

Overall Dimensions:

Length	12.0 in; 53.9 cm
Diameter (anode mounting flange)	6.75 in; 17.1 cm

Net Weight 17 lbs; 6.4 kg

Maximum Operating Temperature:

Ceramic/Metal Seals & Envelope	250 Deg.C
--	-----------

Operating Position Axis Vertical, Base Up or Down

Base Special Coaxial

Recommended Air System Socket EIMAC SK-1300

Cooling Liquid & Forced Air

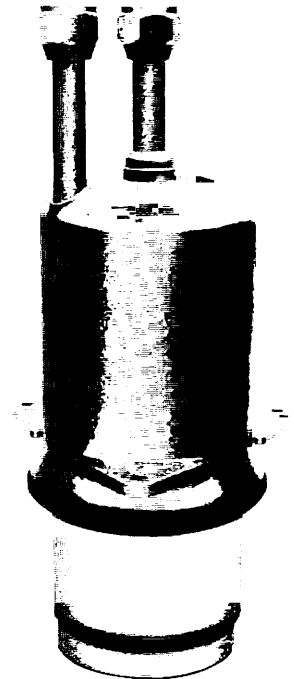



RADIO FREQUENCY POWER AMPLIFIER

Typical Operation - Grid Driven

Class C Telegraphy or FM

Plate Voltage	10.0	kVdc
Plate Current	7.0	Adc
Grid Bias Voltage	-300	Vdc
Grid Current *	1.5	Adc
Peak Positive Grid Voltage *	320	v
Driving Power *	800	W
Plate Input Power *	70	kW
Plate Dissipation *	10	kW
Plate Output Power *	60	kW
Approximate Load Impedance	800	Ohms

ABSOLUTE MAXIMUM RATINGS:

DC PLATE VOLTAGE	12.0	KILOVOLTS
DC PLATE CURRENT	9.0	AMPERES
DC GRID VOLTAGE	-1.2	KILOVOLTS
GRID DISSIPATION	1000	WATTS
PLATE DISSIPATION	40	KILOWATTS

* Approximate, will vary with installation

TYPICAL OPERATION values are obtained by calculation from published characteristic curves. Adjustment of the rf grid voltage to obtain the specified plate current at the specified bias and plate voltage is assumed. If this procedure is followed, there will be little variation in output power when the tube is replaced, even though there may be some variation in grid current. The grid current which occurs when the desired plate current is obtained is incidental and may vary from tube to tube. This current variation causes no performance degradation providing the circuit maintains the correct voltage in the presence of the current variation. If grid bias is obtained principally by means of a grid resistor, the resistor must be adjusted to produce the required bias voltage when the correct rf grid voltage is applied.

RANGE VALUES FOR EQUIPMENT DESIGN:

	<u>MIN.</u>	<u>MAX.</u>	
Filament Current @ 12.0 volts	115	125	A
Interelectrode Capacitance ¹ (grounded cathode connection)			
C _{in}	65.0	75.0	pF
C _{out}	2.0	2.6	pF
C _{gp}	38.0	48.0	pF

¹ Capacitance values are for a cold tube as measured in a shielded fixture.

A P P L I C A T I O N

MECHANICAL

MOUNTING - The tube must be mounted by means of the three anode flanges, with its axis vertical. The base of the tube may be up or down at the convenience of the designer.

SOCKET - The EIMAC socket SK-1300 should be used for contact to the filament and grid terminals as its construction simplifies forced-air cooling of this section of the tube.

COOLING - The anode of the 3CW40,000A5 is cooled by circulating water through the integral anode water jacket. The table lists minimum water flow rates for various plate dissipation levels, based on a water temperature rise of 15°C. Outlet water temperature should never exceed 70°C, and where long life and consistent performance are factors the designer is cautioned that cooling in excess of minimum requirements is normally beneficial.



Plate Diss. (kW)	Water Flow (gpm)	Approx. Press. (psi)
20	15	19
30	16	21
40	17	24

When the tube is mounted anode up the outer cooler pipe should be used as the water inlet. If mounted anode down, the center cooler pipe should be used as the water inlet.

High velocity water flow is required to maintain high thermal efficiency. Cooling water must be well filtered (with effectiveness the equivalent of a 100-mesh screen) to eliminate any solid materials, to avoid the possibility of blockage of any cooling passages, as this would immediately affect cooling efficiency and could produce localized anode overheating and failure of the tube.

Tube life can be seriously compromised by the cooling water condition. If it becomes contaminated, deposits will form on the inside of the water jacket, causing localized anode heating and eventual tube failure. To insure minimum electrolysis and power loss, the water resistance at 25 °C should always be one megohm per cubic centimeter or higher. The relative water resistance can be continuously monitored in the reservoir by readily available instruments.

EIMAC Application Bulletin #16, WATER PURITY REQUIREMENTS IN LIQUID COOLING SYSTEMS, is available on request, and contains considerable detail on purity requirements and maintenance systems.

Forced-air cooling of the tube base is required to maintain filament and grid seal temperatures at safe operation levels. An air flow of approximately 50 to 100 cfm at 50 °C maximum at sea level should be directed through and around the EIMAC SK-1300 socket, toward the filament and grid seal areas. Particular attention should be paid to the center recessed section of the base, with air specifically directed here if necessary. Temperature sensitive paints are available for testing before an equipment design is finalized.

Both anode and base cooling should be applied before or simultaneously with the application of electrode voltages, including the tube filament. Sixty to eighty percent of the filament power appears as heat in the anode, and in the absence of coolant flow temperatures will rise to levels which are detrimental to long life. If the coolant lines are blocked the coolant jacket may rupture

from the generated steam pressure. Cooling should normally continue for a short period after removal of electrode voltages to allow the tube to cool down properly.

It is considered good engineering practice to provide interlock circuitry so that if either base or anode cooling is impaired or fails all power will be removed from the tube immediately.

ELECTRICAL

ABSOLUTE MAXIMUM RATINGS - The values shown for each type of service are based on the "absolute system" and are not to be exceeded under any service conditions. These ratings are limiting values outside which the serviceability of the tube may be impaired. In order not to exceed absolute ratings the equipment designer has the responsibility of determining an average design value for each rating below the absolute value of that rating by a safety factor so that the absolute values will never be exceeded under any usual conditions of supply voltage variation in the equipment itself. It does not necessarily follow that combinations of absolute maximum ratings can be attained simultaneously.

FILAMENT OPERATION - During turn-on the filament inrush current should be limited to 250 amperes. At rated (nominal) filament voltage the peak emission capability of the tube is many times that needed for communication service. A reduction in filament voltage will lower the filament temperature, which will substantially increase life expectancy. The correct value of filament voltage should be determined for the particular application. It is recommended the tube be operated at full nominal voltage for an initial stabilization period of 100 to 200 hours before any action is taken to operate at reduced voltage. The voltage should gradually be reduced until there is a slight degradation in performance (such as power output or distortion). The filament voltage should then be increased one tenth of a volt above the value where performance degradation was noted for operation. The operating point should be rechecked after 24 hours. Filament voltage should be closely regulated when voltage is to be reduced below nominal in this manner, to avoid any adverse influence by normal line voltage variations.

Filament voltage should be measured at the tube base or socket, using an accurate rms-responding meter. Periodically throughout the life of the



tube the procedure outlined above for reduction of voltage should be repeated, with voltage reset as required, to assure best tube life.

GRID OPERATION - The maximum control grid dissipation is 1000 watts, determined approximately by the product of the dc grid current and the peak positive grid voltage. A protective spark-gap device should be connected between the control grid and the filament to guard against excessive voltage.

FAULT PROTECTION - In addition to the normal plate over-current interlock and coolant interlock, the tube must be protected from internal damage caused by an internal plate arc which may occur at high plate voltage. A protective resistance should always be connected in series with the tube anode, to help absorb power supply stored energy if an internal arc should occur. An electronic crowbar, which will discharge power supply capacitors in a few microseconds after the start of an arc, is recommended. The protection criteria for each electrode supply is to short each electrode to ground, one at a time, through a vacuum relay switch and a 6-inch length of #30 AWG copper wire. The wire will remain intact if the criteria is met.

EIMAC Application Bulletin #17 titled **FAULT PROTECTION** contains considerable detail, and is available on request.

HIGH VOLTAGE - Normal operating voltages used with this tube are deadly, and the equipment must be designed properly and operating precautions must be followed. Design all equipment so that no one can come in contact with high voltages. All equipment must include safety enclosures for high-voltage circuits and terminals, with interlock switches to open primary circuits of the power supply and to discharge high-voltage capacitors whenever access doors are opened. Interlock switches must not be bypassed or "cheated" to allow operation with access doors open. Always remember that **HIGH VOLTAGE CAN KILL**.

RADIO-FREQUENCY RADIATION - Avoid exposure to strong rf fields even at relatively low frequency. Absorption of rf energy by human tissue is dependent on frequency. Under 300 MHz most of the energy will pass completely through the human body with little attenuation or heating affect. Public health agencies are concerned with the hazard even at these frequencies. Prolonged exposure to rf radiation should be limited to 10 milliwatts per square centimeter (Occupational Safety and Health Administration (OSHA) standard).

INTERELECTRODE CAPACITANCE - The actual internal interelectrode capacitance of a tube is influenced by many variables in most applications, such as stray capacitance to the chassis, capacitance added by the socket used, stray capacitance between tube terminals, and wiring effects. To control the actual capacitance values within the tube, as the key component involved, the industry and Military Services use a standard test procedure as described in Electronic Industries Association Standard RS-191. This requires the use of specially constructed test fixtures which effectively shield all external tube leads from each other and eliminates any capacitance reading to "ground". The test is performed on a cold tube. Other factors being equal, controlling internal tube capacitance in this way normally assures good interchangeability of tubes over a period of time. The capacitance values shown in the manufacturer's technical data normally are taken in accordance with Standard RS-191.

The equipment designer is therefore cautioned to make allowance for the actual capacitance values which will exist in any normal application. Measurements should be taken with the mounting which represent approximate final layout if capacitance values are highly significant in the design.

SPECIAL APPLICATIONS - When it is desired to operate this tube under conditions widely different from those listed here, write to Varian EIMAC; attn: Applications Engineering; 301 Industrial Way; San Carlos, CA 94070 U.S.A.



OPERATING HAZARDS

PROPER USE AND SAFE OPERATING PRACTICES WITH RESPECT TO POWER TUBES ARE THE RESPONSIBILITY OF EQUIPMENT MANUFACTURERS AND USERS OF SUCH TUBES. ALL PERSONS WHO WORK WITH OR ARE EXPOSED TO POWER TUBES OR EQUIPMENT WHICH UTILIZES SUCH TUBES MUST TAKE PRECAUTIONS TO PROTECT THEMSELVES AGAINST POSSIBLE SERIOUS BODILY INJURY. DO NOT BE CARELESS AROUND SUCH PRODUCTS.

The operation of this tube may involve the following hazards, any one of which, in the absence of safe operating practices and precautions, could result in serious harm to personnel:

- | | |
|--|--|
| a. HIGH VOLTAGE - Normal operating voltages can be deadly. | c. HOT WATER - Water used to cool tubes may reach scalding temperatures. Touching or rupture of the cooling system can cause serious burns. |
| b. RF RADIATION - Exposure to strong rf fields should be avoided, even at relatively low frequencies. The dangers of rf radiation are more severe at UHF and microwave frequencies and can cause serious bodily and eye injuries. CARDIAC PACEMAKERS MAY BE EFFECTED. | d. HOT SURFACES - Surfaces of air-cooled radiators and other parts of tubes can reach temperatures of several hundred Degrees C and cause serious burns if touched for several minutes after all power is removed. |

Please review the detailed operating hazards sheet enclosed with each tube, or request a copy from: Varian EIMAC, Power Grid Tube Division, 301 Industrial Way, San Carlos CA 94070.

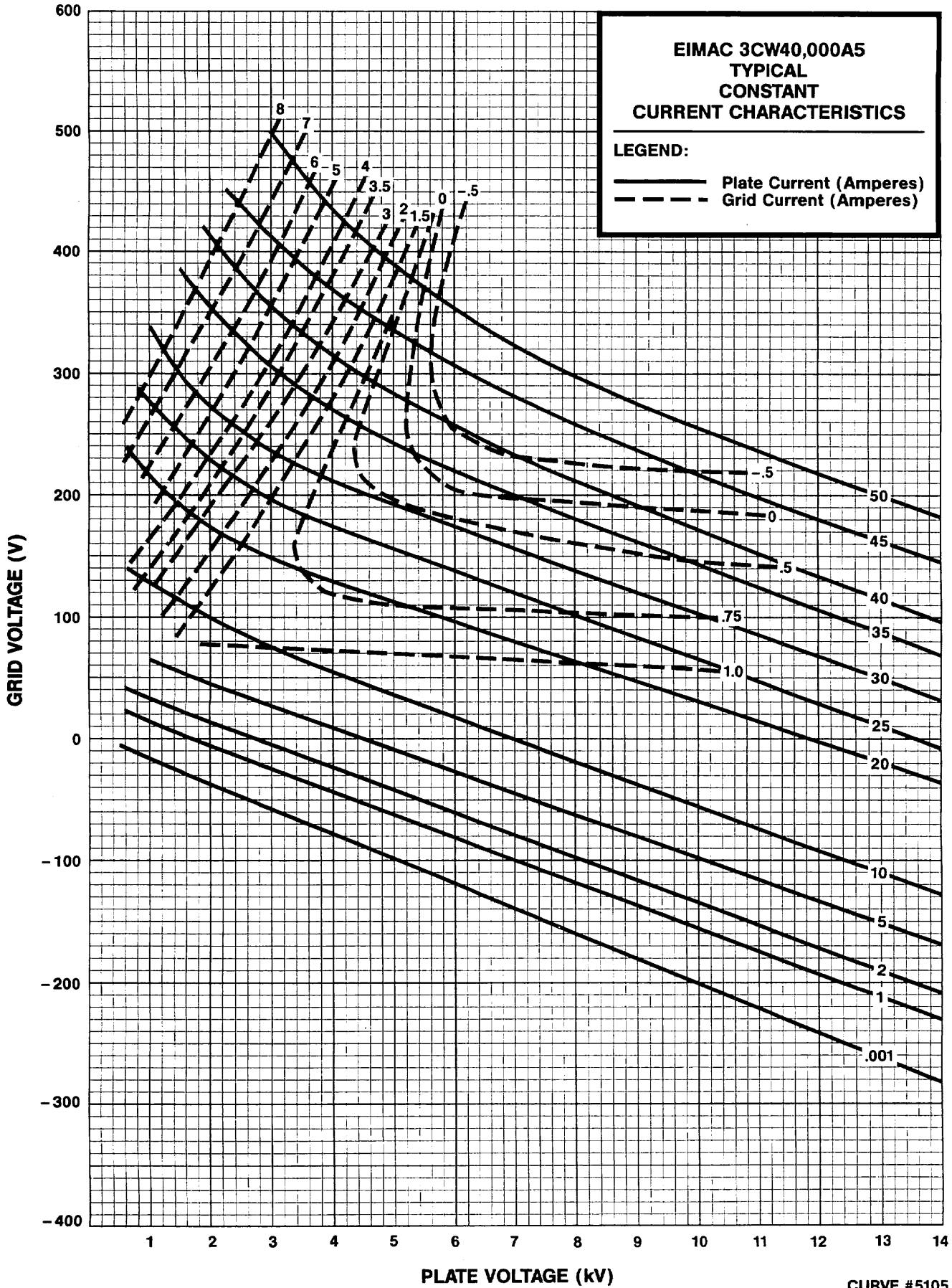

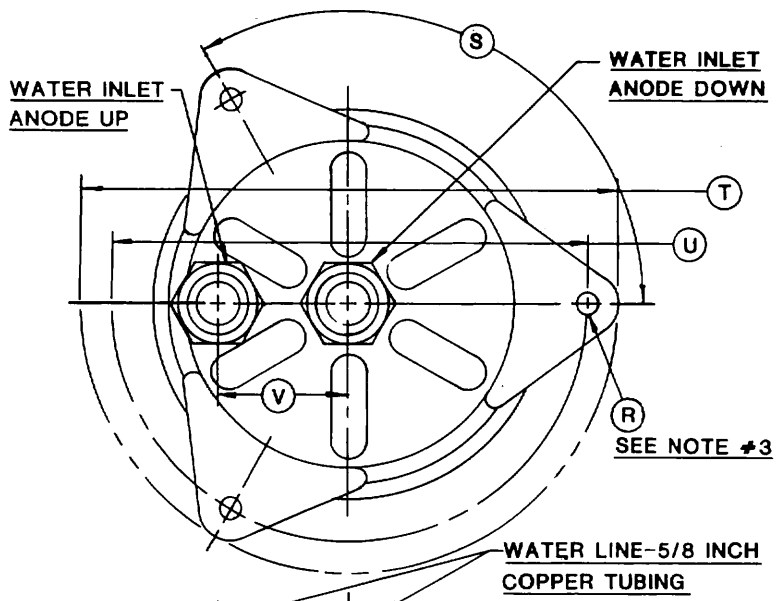

DIM	INCHES			MILLIMETERS		
	MIN	MAX	REF	MIN.	MAX.	REF
A	4.062	4.188				
B			4.925			
C	.600	.760				
D	1.896	1.936				
E	3.133	3.173				
F	3.792	3.832				
G	.988	1.050				
H	.188					
J	.188					
K			.712			
L	4.350	4.450				
M			.250			
N	9.400	9.600				
P			2.625			
R			.265			
S	118°	122°				
T			6.750			
U	5.957	6.025				
V			1.625			

NOTES:

1. REF DIMENSIONS ARE FOR INFO ONLY & ARE NOT REQUIRED FOR INSPECTION PURPOSES.
2. (*) CONTACT SURFACE
3. 3 MOUNTING HOLES IN MOUNTING LUGS

